

ETAP 2010





the difference

advantages

UNSINKABLE You will never need to abandon ship thanks to the unsinkability guarantee. You know that your ETAP boat will stay afloat, so you can calmly tackle any technical problems and sail safely to the nearest port.

INSULATION There is a highly efficient thermal and acoustic insulation thanks to the double-mould construction method.

NO CONDENSATION Your ETAP is condensation-free thanks to the ship-in-ship construction, giving your crew and equipment a much more pleasant environment than other boats.

OPTIMAL STIFFNESS An ETAP has a more rigid, dimensionally stable structure thanks to the double-skinned deck and hull.

UNMATCHED QUALITY due to the use of premium quality materials and high production methods.

HIGH RESALE VALUE ETAP yachts have a very high resale value.



ETAP 21i flooded to the maximum. Test by German magazine "Yacht". Itinerary: strait between Germany and Denmark in a single day

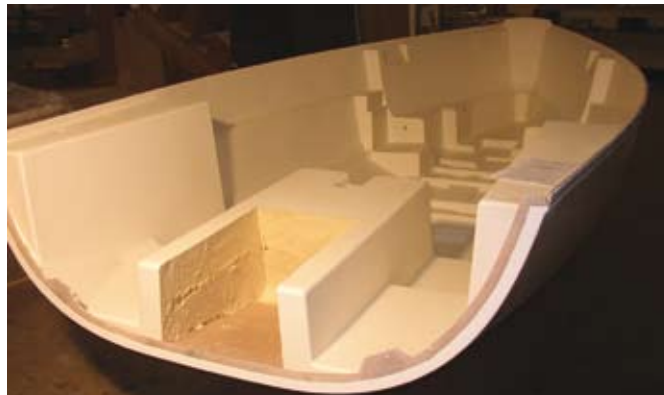

ETAP 21i hull in double-skin construction.



Test by French magazine "Voiles & Voiliers" Itinerary: Calais-Dover-Calais in a single day with through-hull fittings open!



unsinkable

AN UNSINKABLE YACHT SHOULD NOT ONLY STAY AFLOAT, IT HAS TO BE ABLE TO SAIL SAFELY TO THE NEAREST PORT. "Voile & Voiliers" (French magazine) sailed an ETAP 21i with through-hull fittings open in a single day from Calais to Dover and back. Average speed: 5 knots in a 20 knot breeze.

Since its foundation 40 years ago, ETAP's aim is to build the safest sailing yachts in the world. Besides selecting superb materials and paying close attention to ergonomics, we feel it imperative that ETAP yachts should be made unsinkable. The crews who entrust themselves to our yachts have to be sure of a safe voyage, even if their boat takes in water.

UNIQUE TECHNIQUE:

ETAP Yachting uses a double mould construction in which a 2-component polyurethane foam is injected. This foam is called "closed celled" because it is not porous and can hardly absorb any water. It gives sufficient buoyancy to the yacht in case of a leak to keep it afloat under all circumstances.

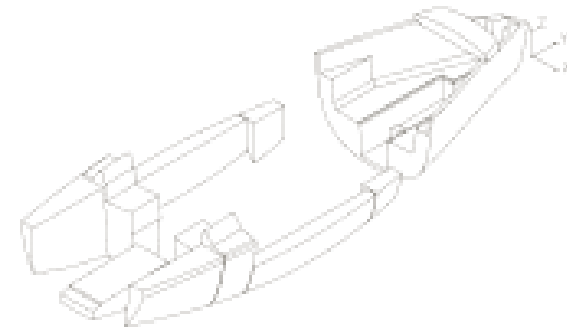
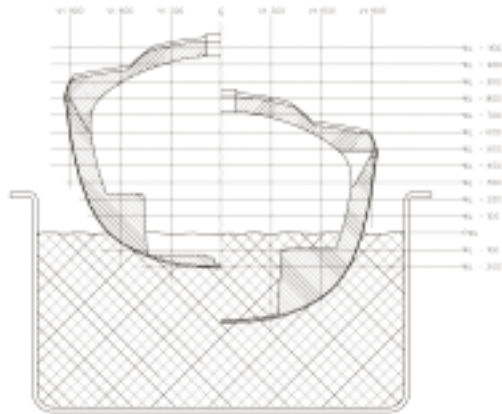

Volume of foam in ETAP 24i

An ETAP who sprang a leak will "float" horizontally and will maintain enough stability to keep aboard safely. In this way, the fault can be remedied depending on the situation and a port can be reached under own power or with the help of a third person.

Difference between a normal and a flooded hull ETAP 21i

ETAP tandem keel

Excellent sailing qualities at reduced draught!

After thorough investigation and numerous tests, ETAP Yachting introduced its ETAP tandem keel. The most important advantages of this keel are the excellent sailing qualities at a considerably reduced draught. This unique design is the result of a co-operation with the architects' bureau Mortain-Mavrikios.

The two most important features to reduce drift, are the size of the lateral plan and its efficiency. The efficiency is defined by the proportion between the depth of the keel and the length. Also a wing section is a classic aid to improve the efficiency.

For a strong reduction of the draught neither a wing keel or a bulb keel were sufficient. The solution was found in placing two shorter keels behind one another, linked by a wing-bulb profile : the ETAP tandem keel.

The ETAP tandem keel gives a better aspect ratio, thus generating more lift.

In addition to increased stability, the wing-bulb also provides better hydrodynamic characteristics.

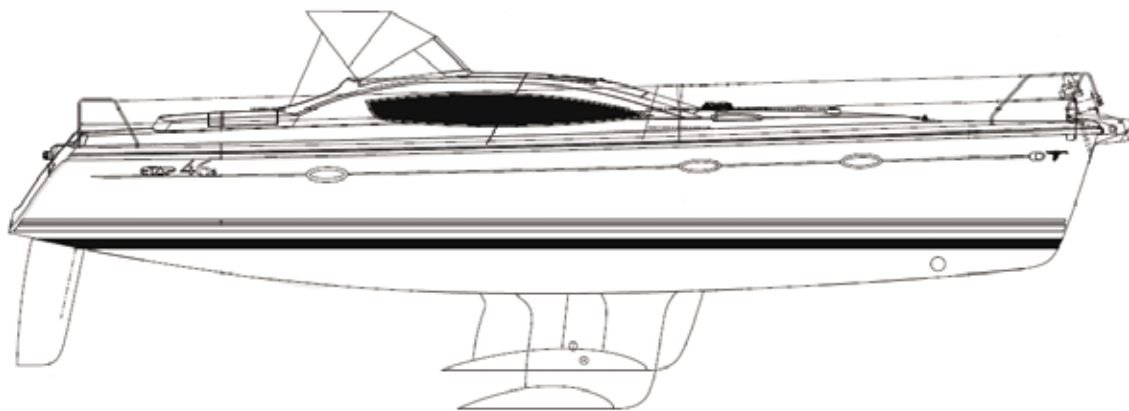

ETAP 22s with a draught of only 0,70 m
ETAP 26s with a draught of only 0,85 m
ETAP 30cq with a draught of only 1,10 m
ETAP 32s with a draught of only 1,30 m
ETAP 37s with a draught of only 1,35 m
ETAP 46DS with a draught of only 1,55 m

ETAP 22s



LOA	6,56 m (21'6")
LWL	6,10 m (20')
Beam	2,49 m / (8'2")
Draught	0,70 m / 1,30 m (2'4" / 4'3")
Displacement	1230 kg / 1180 kg (2711 / 2601 lb)
Ballast	350 kg / 300 kg (771 / 661 lb)
Mastheight	10,40 m (34'1")
Mainsail	15,50 m ² (167 sq ft)
Jib	8,40 m ² (90 sq ft)
Gennaker	22,5 m ² / 34 m ² (242 / 366 sq ft)
Engine	optional
Fuel capacity	optional
Water capacity	20 l

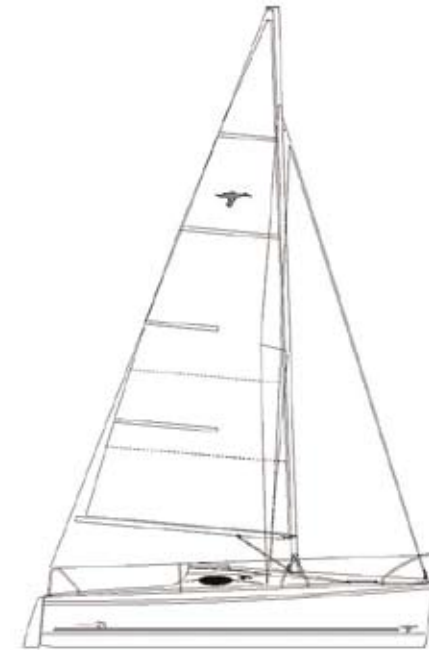

ETAP 26s



LOA	8,02 m (26'4")
LWL	6,71 m (22'0")
Beam	2,50 m (8'2")
Draught	0,85 m / 1,50 m (2'9" / 4'11")
Displacement	1820 kg / 1800 kg (4008 / 3964 lb)
Ballast	520 kg / 500 kg (1145 / 1101 lb)
Mastheight	11,60 m (38'1")
Mainsail	18,20 m ² (169 sq ft)
Jib	12,2 m ² (131 sq ft)
Gennaker	42,1 m ² (453 sq ft)
Engine	optional
Fuel capacity	optional
Water capacity	50 l



ETAP 30cq



LOA	8,98 m (29'5")
LWL	8,45 m (27'9")
Beam	3,36 m (11'3")
Draught	1,10 m / 1,76 m (3'7" / 5'9")
Displacement	3820 kg / 3700 kg (8422 / 8157 lb)
Ballast	1290 kg / 1170 kg (2844 / 2579 lb)
Mastheight	13,05 m (42'10")
Mainsail	25,80 m ² (277 sq ft)
Selftacking jib	15 m ² (161 sq ft)
Genoa	19 m ² (205 sq ft)
Engine	19 HP / 13,8 kW
Fuel capacity	65 l
Water capacity	115 l



ETAP 32s

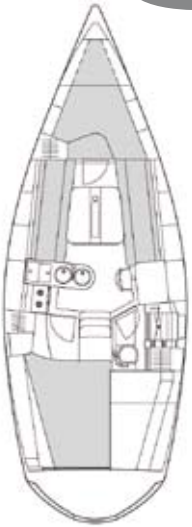

LOA	9,84 m (32'3")
LWL	8,38 m (27'6")
Beam	3,42 m (11'3")
Draught	1,30 m / 1,80 m (4'3" / 5'11")
Displacement	3890 kg / 3700 kg (8575 / 8157 lb)
Ballast	1290 kg / 1100 kg (2844 / 2425 lb)
Mastheight	14,00 m (45'11")
Mainsail	27,20 m ² (293 sq ft)
Genoa	27,60 m ² (297 sq ft)
Gennaker	55,00 m ² (592 sq ft)
Engine	19 HP / 13,8 kW
Fuel capacity	82 l
Water capacity	170 l



ETAP 37s

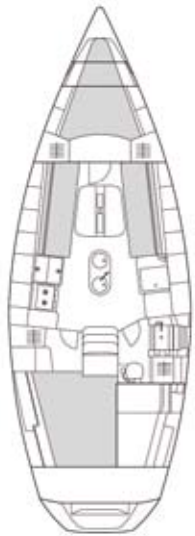

LOA	11,26 m (36'11")
LWL	9,90 m (32'6")
Beam	3,85 m (12'8")
Draught	1,35 m / 1,95 m (4'5" / 6'5")
Displacement	6550 kg / 6350 kg (14427 / 13987 lb)
Ballast	2200 kg / 2000 kg (4846 / 4405 lb)
Mastheight	17,25 m (56'7")
Mainsail	36,10 m ² (389 sq ft)
Genoa	39,70 m ² (427 sq ft)
Gennaker	84 m ² (904 sq ft)
Engine	28 HP / 21 kW
Fuel capacity	116 l
Water capacity	250 l

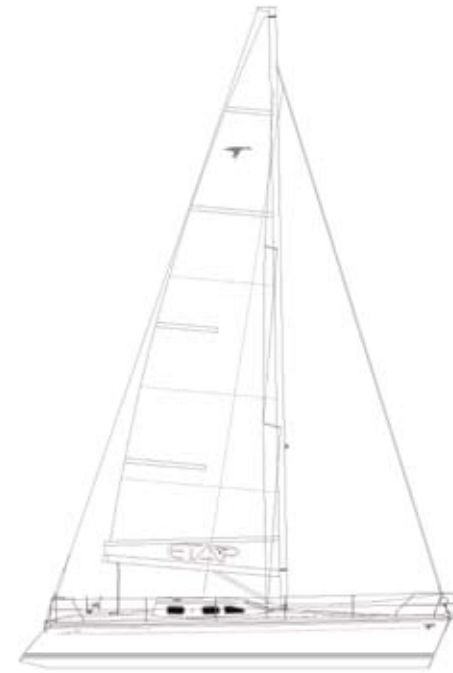

ETAP 48Ds

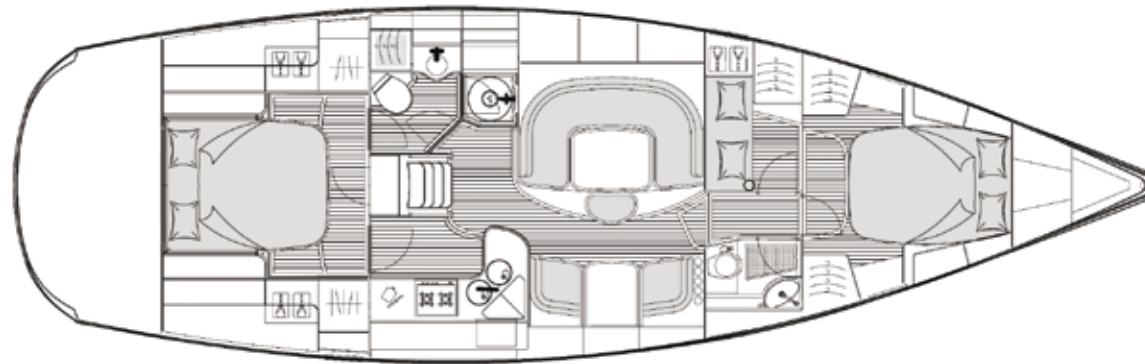



48Ds

LOA 14,46 m (47'5")
LWL 12,50 m (41'00")
Beam 4,40 m (14'5")
Draught 1,55 m / 2,05 m (5'1" / 6'8")
Displacement 12850 kg / 13200 kg (27100 / 26350 lb)
Ballast 4200 kg / 3850 kg (9260 / 8490 lb)
Mastheight 19,85 m (65'1")
Mainsail 54,85 m² (570 sq ft)
Genoa 50,80 m² (547 sq ft)
Gennaker 99,30 m² (1069 sq ft)
Storm jib 14,60 m² (157 sq ft)
Working jib 24,00 m² (258 sq ft)
Engine 75 HP / 55,3 kW
Fuel capacity 280 l
Water capacity 460 l

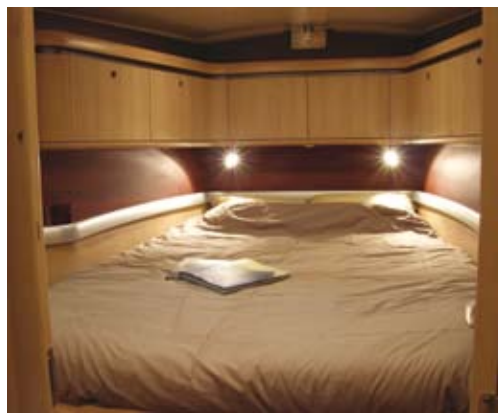

ETAP 1100AC

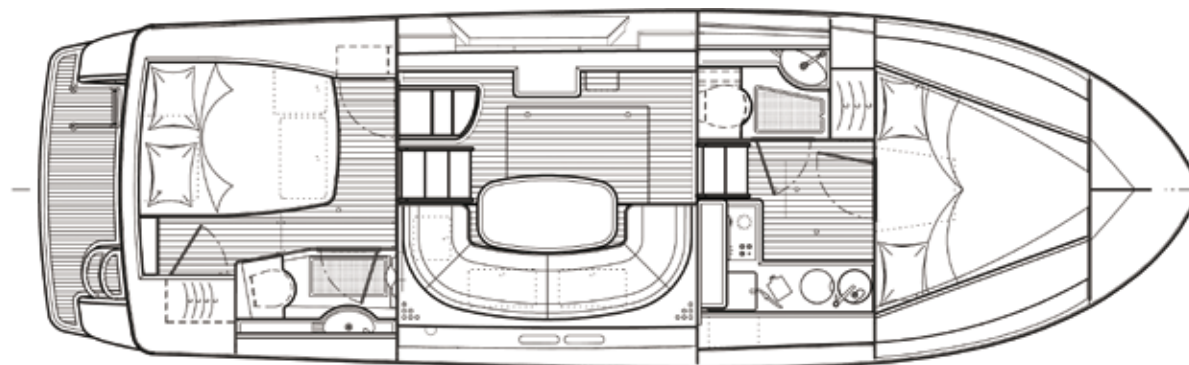

ETAP 1100AC

LOA	11,00 m (36'1")
Beam	3,37 m (11'6")
Draught	1,00 m (3'3")
Air Draught	3,27 m / 4,15 m (10'8" / 13'7") (radar arch down / up)
Weight	6000 kg / 13228 lb
Engine	1 Yanmar engine 100 / 150 (standard) / 260 / 315 HP 2 Volvo Penta engines 160 / 190 HP
Diesel tanks	2 x 300 l
Water tank	400 l
Holding tank	115 l

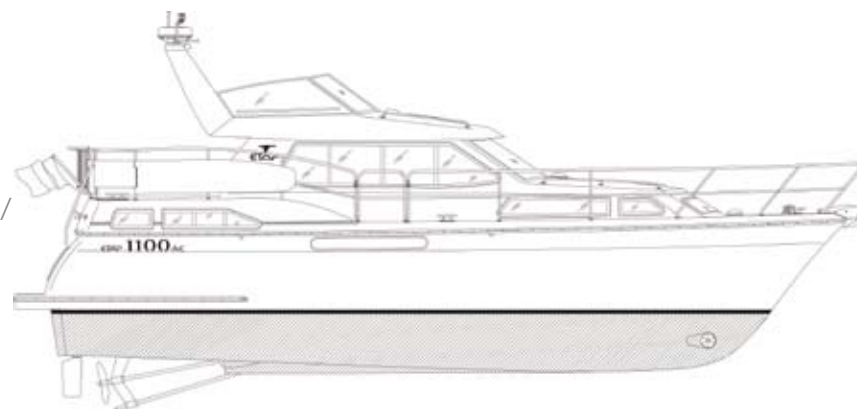

ETAP sails

Etap believes that every Etap yacht only deserves the best .
That is why we developed a brand new sail range , not only for the new models but for every single yacht Etap ever built . A sail specifically designed for a boat - it can't get any better.

KEY FEATURES ETAP FAST CRUISING SAILS

- sails specially developed for every yacht
- maximum control in all conditions
- reliable, strong, durable
- easy handling for maximum pleasure
- minimum effort for maximum output
- same premium quality standard as Etap yachts
- the best performance for your Etap guaranteed



ETAP SAILS . MAKE YOUR ETAP EVEN BETTER.

ETAP facts



HEADQUARTERS: Europe: Lokeren, Belgium
Asia: Cherthala (Cochin), India

7 MODELS from 22 to 48 FT
ETAP adapted the name of each model to its actual length

OVER 7000 YACHTS
in the market

40 YEAR ANNIVERSARY
2010



ETAP is currently expanding its worldwide dealernetwork in order to cover all countries on every continent, for sales, support and service.

ETAP customers:

- private yacht owners
choose for unsinkability, performance, comfort and quality
- charter companies
choose for the lowest operating costs due to the quality, unsinkability and high resale value
- sailing schools
choose for safety, lowest operating costs and possibility to sail in undeeep waters due to the ETAP tandem keel
- shared ownership
choose for a high quality, fast and safe yacht with long-lasting value
- regatta sailors
choose for excellent sailing performance combined with comfort and durability
- residents of tropical areas (Florida)
choose for a qualitative condense-free yacht due to the double-mould construction
- round the world sailors
choose for safety, comfort and extraordinary seaworthiness

YOUR ETAP: A PERFECT SYMPHONY OF SAILING PERFORMANCE, COMFORT AND SAFETY

ETAP quality

Due to the ship-in-ship construction and the use of high quality materials and **suppliers**, ETAP can guarantee that every delivered yacht has **premium quality**. Unlike single-hull yachts, an ETAP looks **as new** even after years of use. The inner deck and inner hull allow us to give our yachts an **unique quality of finish**: there is no need to use water-proof materials or plastic in the decor; instead, the interior is made of sound structural ployester, a low-maintenance, durable and aesthetically pleasing material with long-lasting value.

**VOLVO
PENTA**

SELDÉN
for sailing

Raymarine

Eberspächer

gebo

LEWMAR

ELVSTRØM
SAILS

SEIVA

REICHHOLD

DSM 

SCOTT BADER

LISTER
PETTER

Jefa Steering
SYSTEMS

ETAP adventures

ETAP: THE PROVIDER OF SAFE FREEDOM SINCE 1970

As ETAP yachts are the safest yachts in the world, it makes them ideal yachts for long distance travel. Big or small yacht, ETAP sailors know that they will always arrive safely in the next port.

Since the foundation of ETAP in 1970, many ETAP yachts successfully completed long distance voyages all over the world.

From 2001 to 2003, Hans Babeck and his family (Germany) completed a sailing trip around the world in an ETAP 21i.



Ulani (Switzerland) leaves for a circumnavigation in April 2010. Follow the adventure on <http://www.ochsenbein.ch>



associations

United Kingdom

<http://www.etapowners.org.uk>

France

<http://etap.forumactif.com>

The Netherlands

<http://www.etapclub.nl>





feedback

info@etapyachting.com

Van: Greg Grewe
Verzonden: donderdag 15 oktober 2009 2:48
Aan: ETAP
Onderwerp: Emailing: 10-10-09_1319 photo A very durable 1988 22i
Bijlagen: 10-10-09_1319.jpg



My 1988 22i was blown off its boat lift and spent 3 days partially aground on my rocky shorefront of Green Bay (of Lake Michigan, Great Lakes, USA,) riding in and being bashed by 3 to 5 foot waves in up to 50 MPH winds. As the photo shows, although her superstructure, such as railings, lifelines and other fittings were damaged by riding against an adjacent dock and boat lift for some of that time, her deck/hull remained intact and seaworthy, without leaks. Her mast and rigging were somewhat damaged but remained functional. (The completely destroyed lift is in the background.) I believe most similar sized boats made by current manufacturers, particularly in the USA, would have been bashed to pieces. If your current models are still constructed to the standards of my 22i, than this is a testament to the durability, seaworthiness and survivability of your yachts under extreme conditions. It would be difficult to convince me to sail in anything but an ETAP.

greg grewe



contact

BELGIUM

Etap Yachting NV
Dijkstraat 15
B-9160 Lokeren
Belgium
Tel +32 348 48 46
Fax +32 348 95 16
WEB www.etapyachting.com
MAIL info@etapyachting.com

DUBAI

Etap Yachting Dubai
PO 4896
Umm Al Quwain
Dubai

INDIA

Etap Yachting - MIC India LTD
Shaktheswaram Jn
IN 688 524 Cherthala
(Kerala / Cochin) India



ETAP 46^{DS}

A UNIQUE CHOICE



THE NEW STANDARD

With the 46Ds, ETAP ushers in a new era in sailing: Advanced sailing technology, a high speed potential, an unparalleled design and above all, the unsinkability of all ETAP yachts. For optimal performance, even with a small crew, exclusive comfort and a unique sailing experience...

ETAP 46^{DS}

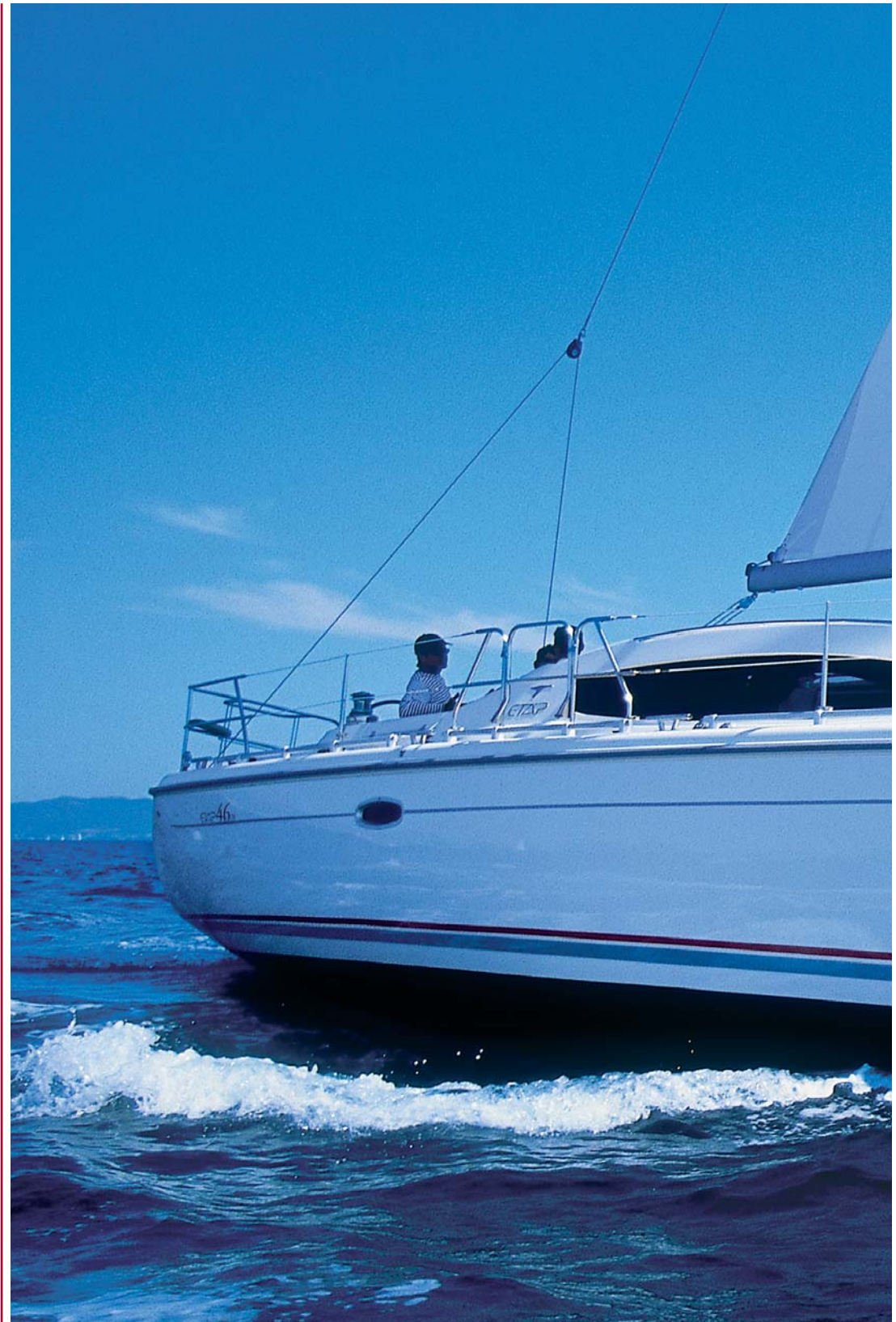







NEW Design by

Stile Bertone



A NEW STYLE

Harmonious lines and pure elegance... the top class of the ETAP 46DS shines through with fine workmanship in the interior. Stile Bertone, the world-renowned Italian design house, has provided a stylish, contemporary decor that exudes luxury and comfort.

ETAP 46DS









- 1 Sitting in the **deck saloon** you can enjoy an excellent view to the outside.
- 2 L-shaped **galley**
- 3 **Fore cabin**

ETAP 46DS





4

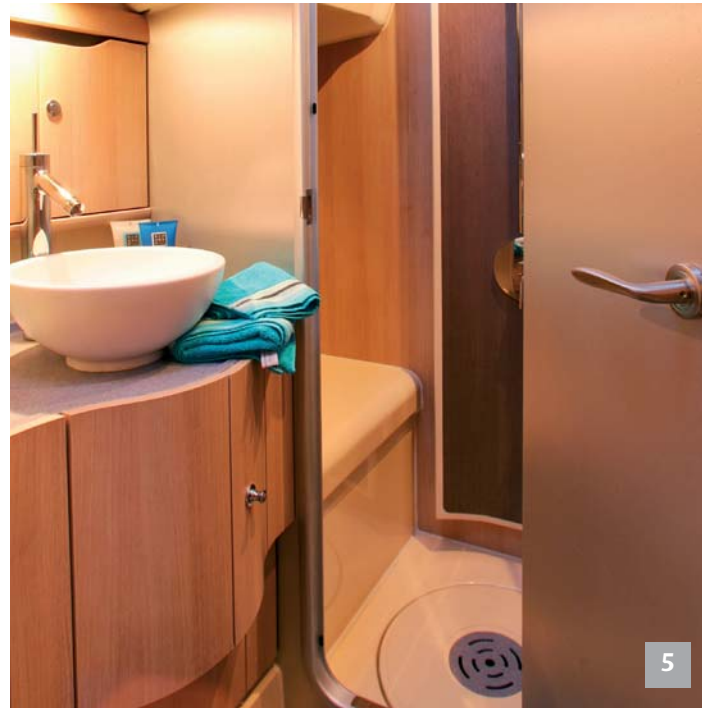

5



6



7

- 4 **Owner's cabin aft**
- 5 **Toilet compartment aft** with separate shower
- 6 **Toilet compartment fore**
- 7 **Middle cabin** or additional utility space

Have a look at our website and browse through the extensive photo gallery of the ETAP 46Ds.

www.etapyachting.com

ETAP YACHTING NV
Steenovenstraat 2
BE - 2390 MALLE
Tel: +32 (0) 3 3124461
Fax: +32 (0) 3 3124466
Internet: www.etapyachting.com
e-mail: info@etapyachting.com

Photographs:
Gilles Martin-Raget
Mike Straub



ETAP Yachting is an
ISO 9001 certified company

Responsible editor: Jan Verhaege,
Steenovenstraat 2, 2390 Malle, Belgium
ref 06-07 E

All details and descriptions contained in this brochure are given for information only, and specifications are subject to change without notice. Equipment shown may not be part of the standard inventory for the model illustrated. Warranty terms and conditions are given in the instruction manual and on our website www.etapyachting.com

