



Turbo şarjlı, direk enjeksiyonlu, tatlı su soğutmalı.

Turbo charged, direct-injection, fresh water cooling.

Çıkış Gücü (Krank) kW (Beygir) / Output (crankshaft) kW (HP)	: 55 kW (75 HP) ISO 8665 veya ISO 3046 standartları / 55 kW (75 HP) ISO 8665 or ISO 3046 standards
Tam Yük Devri / Rpm at full load	: 3200
Silindir Adedi / Cylinders	: 4 silindir - sıra / 4 cylinder - in line
Silindir Hacmi / Displacement (cm ³)	: 2133 cm ³
Piston Çapı / Bore (mm)	: 85 mm
Strok / Stroke (mm)	: 94 mm
Kompresyon Oranı / Compression ratio	: 19/1
Azami Tork / Max. torque (Nm)	: 180 Nm @ 2200
Enjeksiyon Sistemi / Injection system	: 2 aşamalı / Two steps
Standart Alternatör (Amp) / Standard alternator (Amp)	: 90
Elektronik Motor Arıza Tespiti / Electronic engine diagnostic	: Var / Yes
Ağırlık / Weight (Kg)	: 255 Kg
Ağırlık - Güç Orantısı (Kg/Beygir) / Weight per unit of power (Kg/HP)	: 2,32

ŞANZİMAN / GEARBOX:

Model	: ZF 25, ZF 45
Güç Aktarma Sistemi / Clutch system	: Hidrolik disk / Hydraulic disc
Şanzıman Oranı / Gear ratio	: 2,52-2,04-1,56:1
Şaft Kaplın Açılı / Output configuration	: Düz/8 derece aşağıya doğru veya 12 derece V-Drive / Direct 8° down-angle or 12° V-Drive
Kuru Ağırlık / Dry weight (Kg)	: 35 Kg

LOW NOISE MARINE

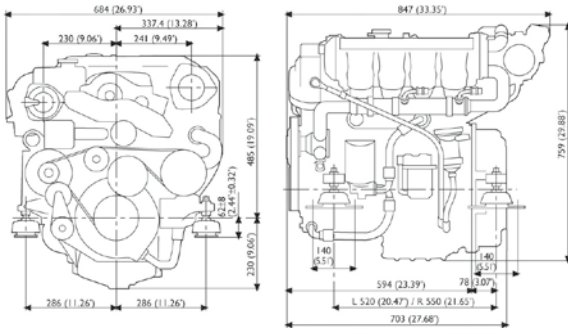

Kod / Code

1566550



Turbo şarjlı, intercooler direkt enjeksiyonlu, tatlı su soğutmalı.

Turbo charged, intercooler direct-injection, fresh water cooling.

Çıkış Gücü (Krank) kW (Beygir) / Output (crankshaft) kW (HP)	: 63 kW (85 HP) ISO 8665 veya ISO 3046 standartları / 63 kW (85 HP) ISO 8665 or ISO 3046 standards
Tam Yük Devri / Rpm at full load	: 3300
Silindir Adedi / Cylinders	: 4 silindir - sıra / 4 cylinder - in line
Silindir Hacmi / Displacement (cm ³)	: 2133 cm ³
Piston Çapı / Bore (mm)	: 85mm
Strok / Stroke (mm)	: 94mm
Kompresyon Oranı / Compression ratio	: 18/1
Azami Tork / Max. torque (Nm)	: 200 Nm @ 2300
Enjeksiyon Sistemi / Injection system	: 2 aşamalı / Two steps
Standart Alternatör (Amp) / Standard alternator (Amp)	: 90
Elektronik Motor Arıza Tespiti / Electronic engine diagnostic	: Var / Yes
Ağırlık / Weight (Kg)	: 243 Kg
Ağırlık - Güç Orantısı (Kg/Beygir) / Weight per unit of power (Kg/HP)	: 2,83

ŞANZİMAN / GEARBOX:

Model	: ZF 25A
Güç Aktarma Sistemi / Clutch system	: Hidrolik disk / Hydraulic disc
Şanzıman Oranı / Gear ratio	: 2,52-2,04-1,56:1
Şaft Kaplın Açılı / Output configuration	: Düz/8 derece aşağıya doğru veya 12 derece V-Drive / Direct 8° down-angle or 12° V-Drive
Kuru Ağırlık / Dry weight (Kg)	: 35 Kg

LOW NOISE MARINE

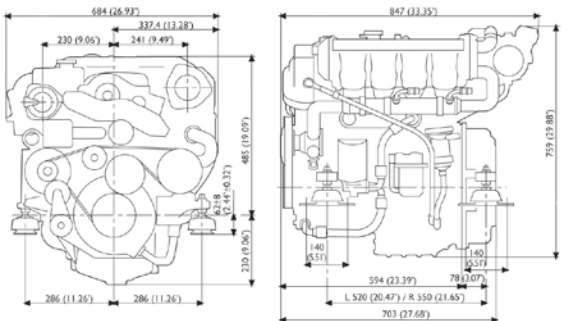

Kod / Code

1566553

MO 114 K 33

STEYR MARINE ENGINES



Turbo şarjlı, intercooler direkt enjeksiyonlu, tatlı su soğutmalı.

Turbo charged, intercooler direct-injection, fresh water cooling.

Çıkış Gücü / Crank) kW (Beygir) / Output (crankshaft) kW (HP)	: 81 kW (110 HP) ISO 8665 veya ISO 3046 standartları / : 81 kW (110 HP) ISO 8665 or ISO 3046 standards
Tam Yük Devri / Rpm at full load	: 3300
Silindir Adedi / Cylinders	: 4 silindir - sıra / 4 cylinder - in line
Silindir Hacmi / Displacement (cm ³)	: 2133 cm ³
Piston Çapı / Bore (mm)	: 85mm
Strok / Stroke (mm)	: 94mm
Kompresyon Oranı / Compression ratio	: 18/1
Azami Tork / Max. torque (Nm)	: 260 Nm @ 2300
Enjeksiyon Sistemi / Injection system	: 2 aşamalı / Two steps
Standart Alternatör (Amp) / Standard alternator (Amp)	: 90
Elektronik Motor Arıza Tespiti / Electronic engine diagnostic	: Var / Yes
Ağırlık / Weight (Kg)	: 255 Kg
Ağırlık - Güç Orantısı (Kg/Beygir) / Weight per unit of power (Kg/HP)	: 2,32

ŞANZİMAN / GEARBOX:

Model	: ZF 25A
Güç Aktarma Sistemi / Clutch system	: Hidrolik disk / Hydraulic disc
Şanzıman Oranı / Gear ratio	: 2,52-2,04-1,56:1
Şaft Kaplin Açılımları / Output configuration	: Düz/8 derece aşağıya doğru veya 12 derece V-Drive / Direct 8° down-angle or 12° V-Drive
Kuru Ağırlık / Dry weight (Kg)	: 35 Kg

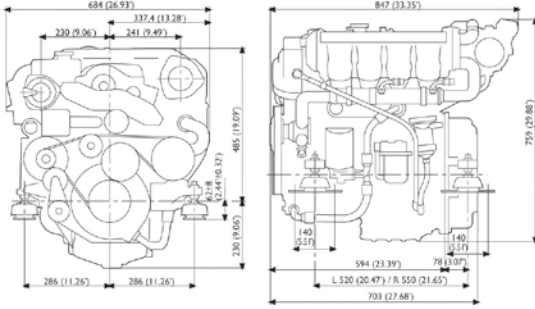
LOW NOISE
MARINE

Kod / Code

1566556

MO 144 M 38

STEYR MARINE ENGINES



Turbo şarjlı, intercooler direkt enjeksiyonlu, tatlı su soğutmalı.

Turbo charged, intercooler direct-injection, fresh water cooling.

Çıkış Gücü / Crank) kW (Beygir) / Output (crankshaft) kW (HP)	: 106 kW (144 HP) ISO 8665 veya ISO 3046 standartları / : 106 kW (144 HP) ISO 8665 or ISO 3046 standards
Tam Yük Devri / Rpm at full load	: 3800
Silindir Adedi / Cylinders	: 4 silindir - sıra / 4 cylinder - in line
Silindir Hacmi / Displacement (cm ³)	: 2133 cm ³
Piston Çapı / Bore (mm)	: 85mm
Strok / Stroke (mm)	: 94mm
Kompresyon Oranı / Compression ratio	: 18/1
Azami Tork / Max. torque (Nm)	: 288 Nm @ 2800
Enjeksiyon Sistemi / Injection system	: 2 aşamalı / Two steps
Standart Alternatör (Amp) / Standard alternator (Amp)	: 90
Elektronik Motor Arıza Tespiti / Electronic engine diagnostic	: Var / Yes
Ağırlık / Weight (Kg)	: 258 Kg
Ağırlık - Güç Orantısı (Kg/Beygir) / Weight per unit of power (Kg/HP)	: 1,79

ŞANZİMAN / GEARBOX:

Model	: ZF 45A
Güç Aktarma Sistemi / Clutch system	: Hidrolik disk / Hydraulic disc
Şanzıman Oranı / Gear ratio	: 2,52-2,04-1,56:1
Şaft Kaplin Açılımları / Output configuration	: Düz/8 derece aşağıya doğru veya 12 derece V-Drive / Direct 8° down-angle or 12° V-Drive
Kuru Ağırlık / Dry weight (Kg)	: 35 Kg

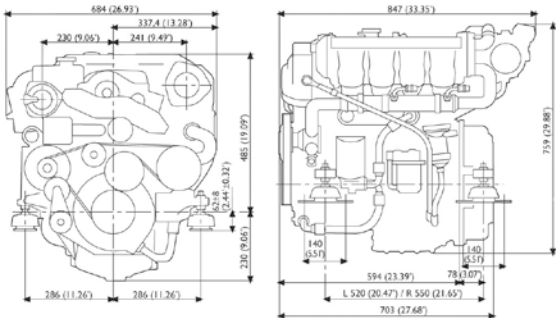

Kod / Code

1566559



Turbo şarjlı, intercooler direkt enjeksiyonlu, tatlı su soğutmalı.

Turbo charged, intercooler direct-injection, fresh water cooling.

Çıkış Gücü (Krank) kW (Beygir) / Output (crankshaft) kW (HP)	: 106 kW (144 HP) ISO 8665 veya ISO 3046 standartları / 106 kW (144 HP) ISO 8665 or ISO 3046 standards
Tam Yük Devri / Rpm at full load	: 3800
Silindir Adedi / Cylinders	: 4 silindir - sıralı / 4 cylinder - in line
Silindir Hacmi / Displacement (cm ³)	: 2133 cm ³
Piston Çapı / Bore (mm)	: 85mm
Strok / Stroke (mm)	: 94mm
Kompresyon Oranı / Compression ratio	: 18/1
Azami Tork / Max. torque (Nm)	: 320 Nm @ 1900
Enjeksiyon Sistemi / Injection system	: 2 aşamalı / Two steps
Standart Alternatör (Amp) / Standard alternator (Amp)	: 90
Elektronik Motor Arıza Tespiti / Electronic engine diagnostic	: Var / Yes
Ağırlık / Weight (Kg)	: 258 Kg
Ağırlık - Güç Orantısı (Kg/Beygir) / Weight per unit of power (Kg/HP)	: 1,79

ŞANZİMAN / GEARBOX:

Model	: ZF 45
Güç Aktarma Sistemi / Clutch system	: Hidrolik disk / Hydraulic disc
Şanzıman Oranı / Gear ratio	: 2,52-2,04-1,56:1
Şaft Kaplin Açılımları / Output configuration	: Düz/8 derece aşağıya doğru veya 12 derece V-Drive / Direct 8° down-angle or 12° V-Drive
Kuru Ağırlık / Dry weight (Kg)	: 35 Kg
Stern Drive (Opsiyonel / Optional)	: MerCruiser Bravo I, II, III

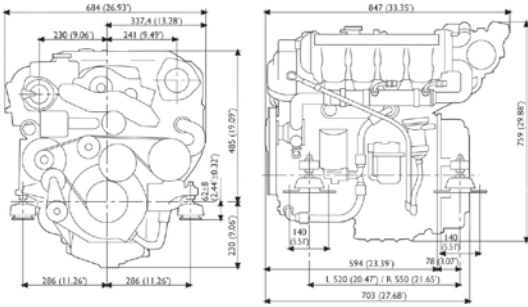

Kod / Code

1566562



Turbo şarjlı, intercooler direkt enjeksiyonlu, tatlı su soğutmalı.

Turbo charged, intercooler direct-injection, fresh water cooling.

Çıkış Gücü (Krank) kW (Beygir) / Output (crankshaft) kW (HP)	: 120 kW (163 HP) ISO 8665 veya ISO 3046 standartları / 120 kW (163 HP) ISO 8665 or ISO 3046 standards
Tam Yük Devri / Rpm at full load	: 4000
Silindir Adedi / Cylinders	: 4 silindir - sıralı / 4 cylinder - in line
Silindir Hacmi / Displacement (cm ³)	: 2133 cm ³
Piston Çapı / Bore (mm)	: 85mm
Strok / Stroke (mm)	: 94mm (3,7")
Kompresyon Oranı / Compression ratio	: 17/1
Azami Tork / Max. torque (Nm)	: 320 Nm @ 2800
Enjeksiyon Sistemi / Injection system	: 2 aşamalı / Two steps
Standart Alternatör (Amp) / Standard alternator (Amp)	: 90
Elektronik Motor Arıza Tespiti / Electronic engine diagnostic	: Var / Yes
Ağırlık / Weight (Kg)	: 258 Kg
Ağırlık - Güç Orantısı (Kg/Beygir) / Weight per unit of power (Kg/HP)	: 1,58

ŞANZİMAN / GEARBOX:

Model	: ZF 45A
Güç Aktarma Sistemi / Clutch system	: Hidrolik disk / Hydraulic disc
Redüksiyon Oranları / Gear ratio	: 2,52-2,04-1,56:1
Şaft Kaplin Açılımları / Output configuration	: Düz/8 derece aşağıya doğru veya 12 derece V-Drive / Direct 8° down-angle or 12° V-Drive
Kuru Ağırlık / Dry weight (Kg)	: 35 Kg

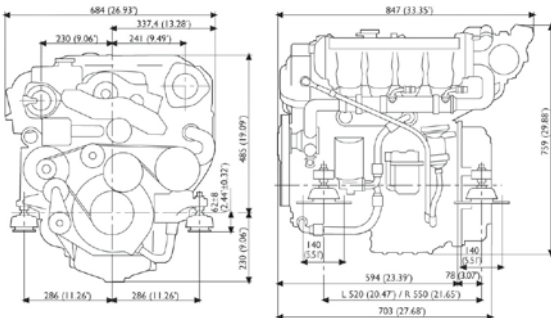

Kod / Code

1566565

MO 174 V 40

STEYR MARINE ENGINES



Turbo şarjlı, intercooler direkt enjeksiyonlu tatlı su soğutmalı.

Turbo charged, intercooler direct-injection, fresh water cooling.

Çıkış Gücü (Krank) kW (Beygir) / Output (crankshaft) kW (HP)	: 125 kW (170 HP) ISO 8665 veya ISO 3046-1
Tam Yük Devri / Rpm at full load	: 4000
Silindir Adedi / Cylinders	: 4 silindir - sıra / 4 in line
Silindir Hacmi / Displacement (cm3)	: 2133 cm ³
Piston Çapı / Bore (mm)	: 85mm
Strok / Stroke (mm)	: 94mm
Kompresyon Oranı / Compression ratio	: 17,5/1
Azami Tork / Max. torque (Nm)	: 300 Nm @ 1800
Enjeksiyon Sistemi / Injection system	: 2 aşamalı enjektörler / Two stage unit in injectors
Standart Alternatör (Amp) / Standard alternator (Amp)	: 90
Elektronik Motor Arıza Tespiti / Electronic engine diagnostic	: Var / Yes
Ağırlık / Weight (Kg)	: 258 Kg
Ağırlık - Güç Orantısı (Kg/Beygir) / Weight per unit of power (Kg/HP)	: 1,56

ŞANZİMAN / GEARBOX:

Model	: ZF 45, ZF 45A, ZF 45C
Güç Aktarma Sistemi / Clutch system	: Hidrolik disk / Hydraulic disc
Şanzıman Oranı / Gear ratio	: 2,52-2,04-1,56-1,26:1
Şaft Kaplin Açılırları / Output configuration	: Düz/8 derece aşağıya doğru veya 12 derece V-Drive / Direct 8° down-angle or 12° V-Drive
Kuru Ağırlık / Dry weight (Kg)	: 35 Kg

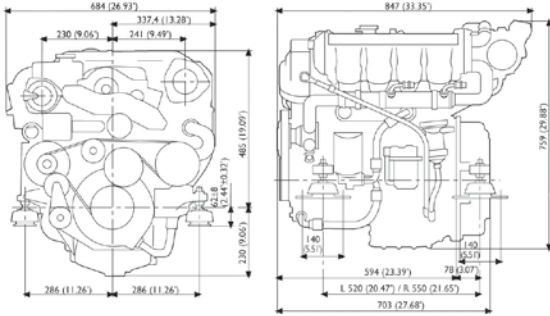

Kod / Code

1566568

SE 156 E 26

STEYR MARINE ENGINES



Turbo şarjlı, intercooler direkt enjeksiyonlu, tatlı su soğutmalı.

Turbo charged, intercooler direct-injection, fresh water cooling.

Çıkış Gücü (Krank) kW (Beygir) / Output (crankshaft) kW (HP)	: 110 kW (150 HP) ISO 8665 veya ISO 3046 standartları / 110 kW (150 HP) ISO 8665 or ISO 3046 standards
Tam Yük Devri / Rpm at full load	: 2600
Silindir Adedi / Cylinders	: 6 silindir - sıra / 6 cylinder - in line
Silindir Hacmi / Displacement (cm3)	: 3200 cm ³
Piston Çapı / Bore (mm)	: 85mm
Strok / Stroke (mm)	: 94mm
Kompresyon Oranı / Compression ratio	: 17/1
Azami Tork / Max. torque (Nm)	: 450 Nm @ 1800
Enjeksiyon Sistemi / Injection system	: 2 aşamalı enjektörler / Two stage unit in injectors
Standart Alternatör (Amp) / Standard alternator (Amp)	: 120
Elektronik Motor Arıza Tespiti / Electronic engine diagnostic	: Var / Yes
Ağırlık / Weight (Kg)	: 340 Kg
Ağırlık - Güç Orantısı (Kg/Beygir) / Weight per unit of power (Kg/HP)	: 2,27

ŞANZİMAN / GEARBOX:

Model	: ZF 45A, ZF 45H, ZF 63H, ZF 63V
Güç Aktarma Sistemi / Clutch system	: Hidrolik disk / Hydraulic disc
Şanzıman Oranı / Gear ratio	: 2,52-2,04-1,56:1
Şaft Kaplin Açılırları / Output configuration	: Düz/8 derece aşağıya doğru veya 12 derece V-Drive / Direct 8° down-angle or 12° V-Drive
Kuru Ağırlık / Dry weight (Kg)	: 44 Kg

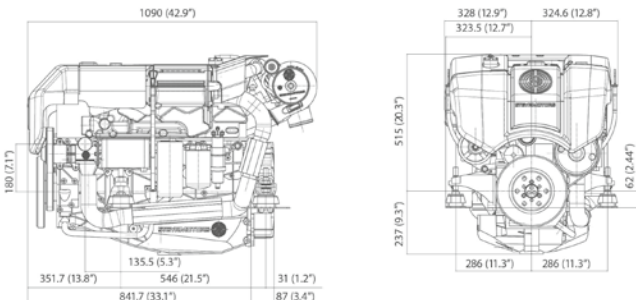

Kod / Code

1566571



Turbo şarjlı, intercooler direk enjeksiyonlu tatlı su soğutmalı.

Turbo charged, intercooler direct-injection, fresh water cooling.

Çıkış Gücü (Krank) kW (Beygir) / Output (crankshaft) kW (HP)	: 140 kW (190 HP) ISO 8665 veya ISO 3046 standartları / : 140 kW (190 HP) ISO 8665 or ISO 3046 standards
Tam Yük Devri / Rpm at full load	: 3500
Silindir Adedi / Cylinders	: 6 silindir - sıra / 6 cylinder - in line
Silindir Hacmi / Displacement (cm ³)	: 3200 cm ³
Piston Çapı / Bore (mm)	: 85mm
Strok / Stroke (mm)	: 94mm
Kompresyon Oranı / Compression ratio	: 17/1
Azami Tork / Max. torque (Nm)	: 445 Nm @ 2050
Enjeksiyon Sistemi / Injection system	: 2 aşamalı enjektörler / two stage unit in injectors
Standart Alternatör (Amp) / Standard alternator (Amp)	: 120
Elektronik Motor Arıza Tespiti / Electronic engine diagnostic	: Var Yes
Ağırlık / Weight (Kg)	: 340 Kg
Ağırlık - Güç Orantısı (Kg/Beygir) / Weight per unit of power (Kg/HP)	: 1,79

ŞANZİMAN / GEARBOX:

Model	: ZF 63
Güç Aktarma Sistemi / Clutch system	: Hidrolik disk / Hydraulic disc
Şanzıman Oranı / Gear ratio	: 2,52-2,04-1,56-1,26:1
Şaft Kaplin Açılı / Output configuration	: Düz/8 derece aşağıya doğru veya 12 derece V-Drive / Direct 8° down-angle or 12° V-Drive
Kuru Ağırlık / Dry weight (Kg)	: 44 Kg

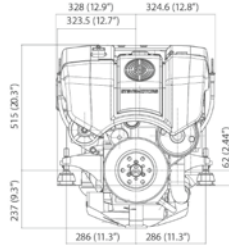
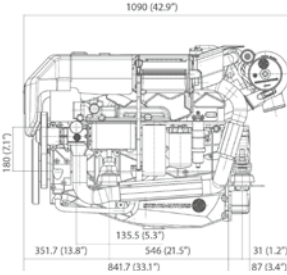
Kod /
Code

1566574

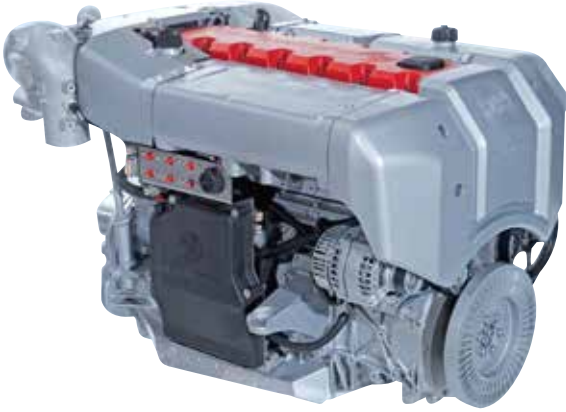

Turbo şarjlı, intercooler direkt enjeksiyonlu, tatlı su soğutmalı.

Turbo charged, intercooler direct-injection, fresh water cooling.

Çıkış Gücü (Krank) kW (Beygir) / Output (crankshaft) kW (HP)	: 170 kW (230 HP) ISO 8665 veya ISO 3046 standartları / : 170 kW (230 HP) ISO 8665 or ISO 3046 standards
Tam Yük Devri / Rpm at full load	: 4000
Silindir Adedi / Cylinders	: 6 silindir - sıra / 6 cylinder - in line
Silindir Hacmi / Displacement (cm ³)	: 3200 cm ³
Piston Çapı / Bore (mm)	: 85mm
Strok / Stroke (mm)	: 94mm
Kompresyon Oranı / Compression ratio	: 17/1
Azami Tork / Max. torque (Nm)	: 470 Nm @ 2550
Enjeksiyon Sistemi / Injection system	: 2 aşamalı enjektörler / two stage unit in injectors
Standart Alternatör (Amp) / Standard alternator (Amp)	: 120
Elektronik Motor Arıza Tespiti / Electronic engine diagnostic	: Var Yes
Ağırlık / Weight (Kg)	: 340 Kg
Ağırlık - Güç Orantısı (Kg/Beygir) / Weight per unit of power (Kg/HP)	: 1,47

ŞANZİMAN / GEARBOX:

Model	: ZF 63H, ZF 63V
Güç Aktarma Sistemi / Clutch system	: Hidrolik disk / Hydraulic disc
Şanzıman Oranı / Gear ratio	: 2,52-2,04-1,56-1,26:1
Şaft Kaplin Açılı / Output configuration	: Düz/8 derece aşağıya doğru veya 12 derece V-Drive / Direct 8° down-angle or 12° V-Drive
Kuru Ağırlık / Dry weight (Kg)	: 44 Kg
Stern Drive (Opsiyonel / Optional)	: MerCruiser Bravo I, II, III

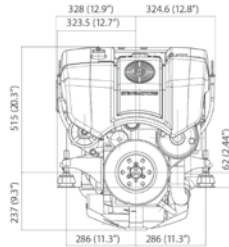
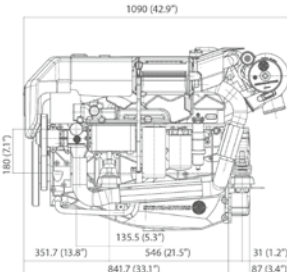
Kod /
Code

1566577

SE 266 S 36

STEYR MARINE ENGINES



Turbo şarjlı, intercooler direkt enjeksiyonlu, tatlı su soğutmalı. Şanzımsız, Jet için.

Turbo charged, intercooler direct-injection, fresh water cooling. Without gearbox, for jetdrives.

Çıkış Gücü (Krank) kW (Beygir) / Output (crankshaft) kW (HP)	: 190 kW (258 HP) ISO 8665 veya ISO 3046 standartları / : 190 kW (258 HP) ISO 8665 or ISO 3046 standards
Tam Yük Devri / Rpm at full load	: 3600
Silindir Adedi / Cylinders	: 6 silindir - sıra / 6 cylinder - in line
Silindir Hacmi / Displacement (cm3)	: 3200 cm ³ (195cid)
Piston Çapı / Bore (mm)	: 85mm (3,35")
Strok / Stroke (mm)	: 94mm (3,7")
Kompresyon Oranı / Compression ratio	: 17/1
Azami Tork / Max. torque (Nm)	: 443 Nm @ 1800
Enjeksiyon Sistemi / Injection system	: 2 aşamalı enjektörler / two stage unit in injectors
Standart Alternatör (Amp) / Standard alternator (Amp)	: 120
Elektronik Motor Arıza Tespiti / Electronic engine diagnostic	: Var Yes
Ağırlık / Weight (Kg)	: 340 Kg
Ağırlık - Güç Orantısı (Kg/Beygir) / Weight per unit of power (Kg/HP)	: 1,32 1,32

ŞANZİMAN / GEARBOX:

Model	: ZF 45A, ZF 45H, ZF 63H, ZF 63V
Güç Aktarma Sistemi / Clutch system	: Hidrolik disk / Hydraulic disc
Redüksiyon Oranları / Gear ratio	: 2,52-2,04-1,56-1.26:1
Şaft Kaplin Açılımları / Output configuration	: Düz/8 derece aşağıya doğru veya 12 derece V-Drive / Direct 8° down-angle or 12° V-Drive
Kuru Ağırlık / Dry weight (Kg)	: 44 Kg (97 Lbs)

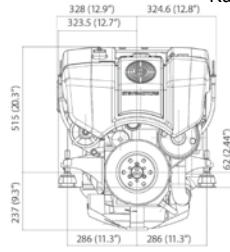
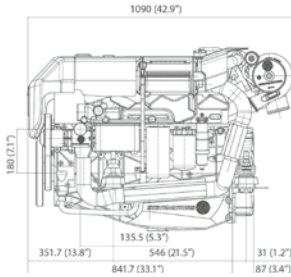
Kod /
Code

1566580

SE 266 E 40

STEYR MARINE ENGINES



Turbo şarjlı, intercooler direkt enjeksiyonlu, tatlı su soğutmalı.

Turbo charged, intercooler direct-injection, fresh water cooling.

Çıkış Gücü (Krank) kW (Beygir) / Output (crankshaft) kW (HP)	: 190 kW (258 HP) ISO 8665 veya ISO 3046 standartları / : 190 kW (258 HP) ISO 8665 or ISO 3046 standards
Tam Yük Devri / Rpm at full load	: 4000
Silindir Adedi / Cylinders	: 6 silindir - sıra / 6 cylinder - in line
Silindir Hacmi / Displacement (cm3)	: 3200 cm ³ (195cid)
Piston Çapı / Bore (mm)	: 85mm (3,35")
Strok / Stroke (mm)	: 94mm (3,7")
Kompresyon Oranı / Compression ratio	: 17/1
Azami Tork / Max. torque (Nm)	: 530 Nm @ 2300 (369° Lb-Ft)
Enjeksiyon Sistemi / Injection system	: 2 aşamalı enjektörler / two stage unit in injectors
Standart Alternatör (Amp) / Standard alternator (Amp)	: 120
Elektronik Motor Arıza Tespiti / Electronic engine diagnostic	: Var Yes
Ağırlık / Weight (Kg)	: 340 Kg
Ağırlık - Güç Orantısı (Kg/Beygir) / Weight per unit of power (Kg/HP)	: 1,32 1,32

ŞANZİMAN / GEARBOX:

Model	: ZF 45A, ZF 45H, ZF 63H, ZF 63V
Güç Aktarma Sistemi / Clutch system	: Hidrolik disk / Hydraulic disc
Redüksiyon Oranları / Gear ratio	: 2,52-2,04-1,56-1.26:1
Şaft Kaplin Açılımları / Output configuration	: Düz/8 derece aşağıya doğru veya 12 derece V-Drive / Direct 8° down-angle or 12° V-Drive
Kuru Ağırlık / Dry weight (Kg)	: 44 Kg (97 Lbs)

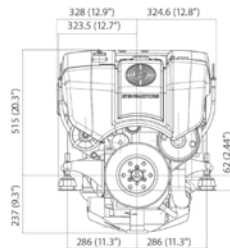
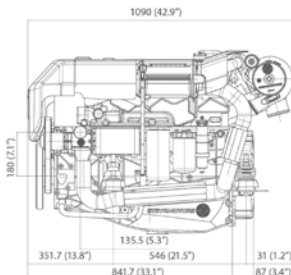
Kod /
Code

1566583



Turbo şarjlı, intercooler direkt enjeksiyonlu, tatlı su soğutmalı.

Turbo charged, intercooler direct-injection, fresh water cooling.

Çıkış Gücü (Krank) kW (Beygir) / Output (crankshaft) kW (HP)	: 205 kW (279 Beygir) ISO 8665 veya ISO 3046-1
Tam Yük Devri / Rpm at full load	: 4000
Silindir Adedi / Cylinders	: 6 silindir - sıra / 6 cylinder - in line
Silindir Hacmi / Displacement (cm ³)	: 3200 cm ³ (195cid)
Piston Çapı / Bore (mm)	: 85mm (3,35")
Strok / Stroke (mm)	: 85mm (3,35")
Kompresyon Oranı / Compression ratio	: 94mm (3,7")
Azami Tork / Max. torque (Nm)	: 17/1
Enjeksiyon Sistemi / Injection system	: 570 Nm @ 2550
Standart Alternatör (Amp) / Standard alternator (Amp)	: 2 aşamalı enjektörler / two stage unit in injectors
Elektronik Motor Arıza Tespiti / Electronic engine diagnostic	: 120
Ağırlık / Weight (Kg)	: Var
Ağırlık - Güç Orantısı (Kg/Beygir) / Weight per unit of power (Kg/HP)	: Yes
	: 340 Kg
	: 1,22
	: 1,20

ŞANZİMAN / GEARBOX:

Model	: ZF 63A, ZF 63V
Güç Aktarma Sistemi / Clutch system	: Hidrolik disk / Hydraulic disc
Redüksiyon Oranları / Gear ratio	: 2,52-2,04-1,56-1,26:1
Şaft Kaplin Açılımları / Output configuration	: Düz/8 derece aşağıya doğru veya 12 derece V-Drive / Direct 8° down-angle or 12° V-Drive
Kuru Ağırlık / Dry weight (Kg)	: 44 Kg (97 Lbs)

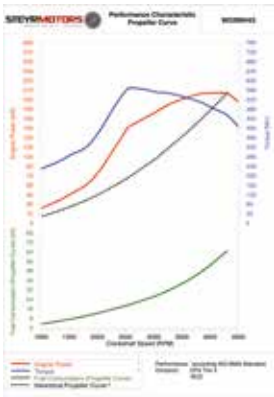

Kod / Code

1566586

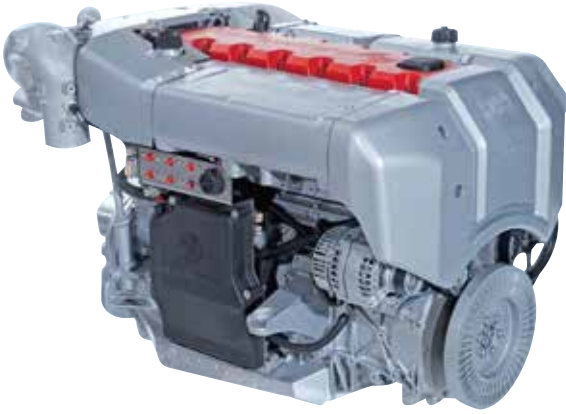

Turbo şarjlı, intercooler direkt enjeksiyonlu, tatlı su soğutmalı. Sadece Water jet sistemlerinde kullanılır!

Turbo charged, intercooler direct-injection, fresh water cooling.

Çıkış Gücü (Krank) kW (Beygir) / Output (crankshaft) kW (HP)	: 215 kW (292 Beygir) ISO 8665 veya ISO 3046-1
Tam Yük Devri / Rpm at full load	: 3800
Silindir Adedi / Cylinders	: 6 silindir - sıra / 6 cylinder - in line
Silindir Hacmi / Displacement (cm ³)	: 3200 cm ³ (195cid)
Piston Çapı / Bore (mm)	: 85mm (3,35")
Strok / Stroke (mm)	: 94mm (3,7")
Kompresyon Oranı / Compression ratio	: 17/1
Azami Tork / Max. torque (Nm)	: 588 Nm @ 3300
Enjeksiyon Sistemi / Injection system	: 2 aşamalı enjektörler / two stage unit in injectors
Standart Alternatör (Amp) / Standard alternator (Amp)	: 120
Elektronik Motor Arıza Tespiti / Electronic engine diagnostic	: Var
Ağırlık / Weight (Kg)	: Yes
Ağırlık - Güç Orantısı (Kg/Beygir) / Weight per unit of power (Kg/HP)	: 340 Kg
	: 1,16
	: 1,16

ŞANZİMAN / GEARBOX:

Model	: ZF 63H, ZF 63V
Güç Aktarma Sistemi / Clutch system	: Hidrolik disk / Hydraulic disc
Redüksiyon Oranları / Gear ratio	: 2,52-2,04-1,56:1
Şaft Kaplin Açılımları / Output configuration	: Düz/8 derece aşağıya doğru veya 12 derece V-Drive / Direct 8° down-angle or 12° V-Drive
Kuru Ağırlık / Dry weight (Kg)	: 44 Kg (97 Lbs)
TRANSMİSYON	: Sadece Water jet sistemlerinde kullanılır! / For Waterjet only!

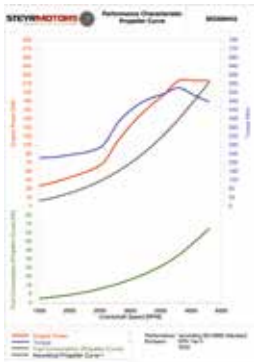

Kod / Code

1566589

MO 144 M 38

STEYR MARINE ENGINES

STEYRMOTORS
INNOVATION WITH LIGHTNESS

+ MERCUISER BRAVO STERDRIVE

Turbo şarjlı, intercooler direkt enjeksiyonlu, tatlı su soğutmalı.

Turbo charged, intercooler direct-injection, fresh water cooling. Without gearbox, for jetdrives.

Çıkış Gücü (Krank) kW (Beygir) /	: 106 kW (144 HP) ISO 8665 veya ISO 3046 normlarına göre /
Output (crankshaft) kW (HP)	: 106 kW (144 HP) ISO 8665 or ISO 3046 standards
Tam Yük Devri / Rpm at full load	: 3800
Silindir Adedi / Cylinders	: 4 silindir - sıra / 4 cylinder - in line
Silindir Hacmi / Displacement (cm3)	: 2133 cm ³ (130cid)
Piston Çapı / Bore (mm)	: 85mm (3,35")
Strok / Stroke (mm)	: 94mm (3,7")
Kompresyon Oranı / Compression ratio	: 18/1
Azami Tork / Max. torque (Nm)	: 288 Nm @ 2800 (212,5' Lb-Ft)
Enjeksiyon Sistemi / Injection system	: 2 aşamalı enjektörler / Two stage unit in injectors
Standart Alternatör (Amp) / Standard alternator (Amp)	: 90
Elektronik Motor Arıza Tespiti / Electronic engine diagnostic	: Var / Yes
Ağırlık / Weight (Kg)	: 258 Kg (567,6 Lbs)
Ağırlık - Güç Orantısı (Kg/Beygir) / Weight per unit of power (Kg/HP)	: 1,79 (3,94 lbs/beygir) / 1,79 (3,94 lbs/HP)

STERNDRIVE (KUYRUK):

MerCruiser	: Bravo I, II
Pervane / Propeller	: 1 (SST opsiyonel / optional)
Şanjman Redüksiyon Oranı / Gear ratio	: 1,5/1,64/1,81/2,0/2,2
Kuru Ağırlık / Dry weight (Kg)	: 111 Kg (222 Lbs)

Kod / Code

1566592

MO 174 V 40

STEYR MARINE ENGINES

STEYRMOTORS
INNOVATION WITH LIGHTNESS

+ MERCUISER BRAVO STERDRIVE

Turbo şarjlı, intercooler direkt enjeksiyonlu, tatlı su soğutmalı.

Turbo charged, intercooler direct-injection, fresh water cooling. Without gearbox, for jetdrives.

Çıkış Gücü (Krank) kW (Beygir) /	: 125 kW (170 HP) ISO 8665 veya ISO 3046-1 standartları
Output (crankshaft) kW (HP)	: 125 kW (170 HP) ISO 8665 or ISO 3046-1 standards
Tam Yük Devri / Rpm at full load	: 4000
Silindir Adedi / Cylinders	: 4 silindir - sıra / 4 in line
Silindir Hacmi / Displacement (cm3)	: 2133 cm ³ (130cid)
Piston Çapı / Bore (mm)	: 85mm (3,35")
Strok / Stroke (mm)	: 94mm (3,7")
Kompresyon Oranı / Compression ratio	: 17/1
Azami Tork / Max. torque (Nm)	: 300 Nm @ 1800
Enjeksiyon Sistemi / Injection system	: 2 aşamalı enjektörler / Two stage in unit injectors
Standart Alternatör (Amp) / Standard alternator (Amp)	: 90
Elektronik Motor Arıza Tespiti / Electronic engine diagnostic	: Var / Yes
Ağırlık / Weight (Kg)	: 258 Kg (567,6 Lbs)
Ağırlık - Güç Orantısı (Kg/Beygir) / Weight per unit of power (Kg/HP)	: 1,56 (3,43 lbs/beygir) / 1,56 (3,43 lbs/HP)

STERNDRIVE (KUYRUK):

MerCruiser	: Bravo I, II, III
Pervane / Propeller	: 1 (SST opsiyonel / optional)
Şanjman Redüksiyon Oranı / Gear ratio	: 1,5/1,64/1,81/2,0/2,2
Kuru Ağırlık / Dry weight (Kg)	: 111 Kg (222 Lbs)

Kod / Code

1566595



+ MERCUISER BRAVO STERDRIVE

Turbo şarjlı, intercooler direkt enjeksiyonlu, tatlı su soğutmalı.

Turbo charged, intercooler direct-injection, fresh water cooling. Without gearbox, for jetdrives.

Çıkış Gücü (Krank) kW (Beygir) /	: 184 kW (250 HP) ISO 8665 veya ISO 3046 standartları /
Output (crankshaft) kW (HP)	: 184 kW (250 HP) ISO 8665 or ISO 3046 standards
Tam Yük Devri / Rpm at full load	: 4500
Silindir Adedi / Cylinders	: 6 silindir - sıra / 6 cylinder - in line
Silindir Hacmi / Displacement (cm3)	: 3200 cm ³
Piston Çapı / Bore (mm)	: 85mm
Strok / Stroke (mm)	: 94mm
Kompresyon Oranı / Compression ratio	: 18/1
Azami Tork / Max. torque (Nm)	: 436 Nm @ 2800
Enjeksiyon Sistemi / Injection system	: 2 aşamalı enjektörler / Two stage in unit injectors
Standart Alternatör (Amp) / Standard alternator (Amp)	: 90
Elektronik Motor Arıza Tespiti / Electronic engine diagnostic	: Var / Yes
Ağırlık / Weight (Kg)	: 305 Kg
Ağırlık - Güç Orantısı (Kg/Beygir) / Weight per unit of power (Kg/HP)	: 1,44

STERNDRIVE (KUYRUK):	
MerCruiser	: Bravo II, III
Pervane / Propeller	: DuaProp (SST opsiyonel / optional)
Şanzıman Oranı / Gear ratio	: 1,65/1,81/2,0/2,2/2,43
Kuru Ağırlık / Dry weight (Kg)	: 113 Kg

Kod / Code

1566597

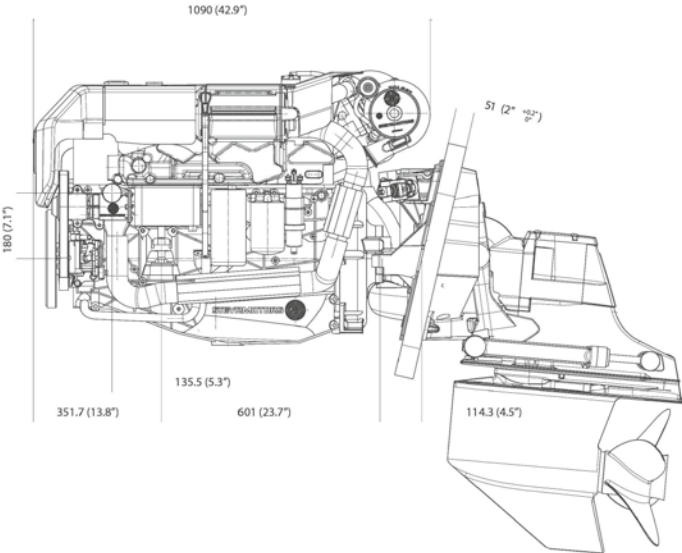

+ MERCUISER BRAVO STERDRIVE

Turbo şarjlı, intercooler direkt enjeksiyonlu, tatlı su soğutmalı.

Turbo charged, intercooler direct-injection, fresh water cooling. Without gearbox, for jetdrives.

Çıkış Gücü (Krank) kW (Beygir) /	: 205 kW (279 Beygir) ISO 8665 veya ISO 3046-1
Output (crankshaft) kW (HP)	: 205 kW (279 HP) ISO 8665 or ISO 3046-1
Tam Yük Devri / Rpm at full load	: 4000
Silindir Adedi / Cylinders	: 6 silindir - sıra / 6 in line
Silindir Hacmi / Displacement (cm3)	: 3200 cm ³
Piston Çapı / Bore (mm)	: 85mm
Strok / Stroke (mm)	: 94mm
Kompresyon Oranı / Compression ratio	: 17/1
Azami Tork / Max. torque (Nm)	: 570 Nm @ 2550
Enjeksiyon Sistemi / Injection system	: 2 aşamalı enjektörler / Two stage in unit injectors
Standart Alternatör (Amp) / Standard alternator (Amp)	: 90
Elektronik Motor Arıza Tespiti / Electronic engine diagnostic	: Var / Yes
Ağırlık / Weight (Kg)	: 340 Kg
Ağırlık - Güç Orantısı (Kg/Beygir) / Weight per unit of power (Kg/HP)	: 1,22

STERNDRIVE (KUYRUK):	
MerCruiser	: Bravo II, III
Pervane / Propeller	: DuaProp (SST opsiyonel / optional)
Şanzıman Oranı / Gear ratio	: 1,65 - 1,81 - 2,00 - 2,20 - 2,43
Kuru Ağırlık / Dry weight (Kg)	: 113 Kg

Kod / Code

1566599