

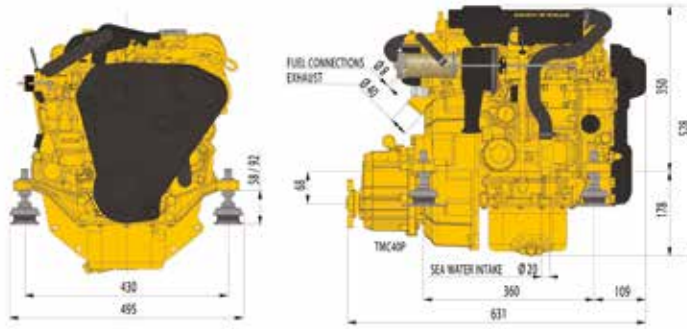

Vetus Diesel M2.13 deniz motoru

Vetus Diesel M2.13 Marine Engine, 12 HP (8.8 kW)

Motor hacmi / Capacity: 635 cm³
 Bor x strok / Bore x Stroke: 76 mm x 70 mm
 Silindir sayısı / Number of cylinder: 2
 Kompresyon oranı / Compression ratio: 23:1
 Alternatör / Alternator: 12V/75A
 Güç / Power: 12 HP (8.8 kW) (ISO 3046-1)
 Maksimum rpm / Maximum RPM: 3000
 Max. Tork 1600 rpm / Max. Torque at 1600 RPM : 32.7 Nm
 Yakıt tüketimi / Fuel consumption: 196 gr/hp/h @ 2500 rpm
 Şanzıman (standart) / Gearbox (Standard): Technodrive TMC40
 Şanzıman oranları / Gearbox ratio: 2.00:1, 2.60:1
 Opsiyonel Şanzımanlar / Optional gearbox: ZF12M (2.11:1, 2.63:1), ZF 15MIV (2.13:1, 2.99:1)
 Ağırlık (şanzıman dahil) / Weight (incl. gearbox): 107kg

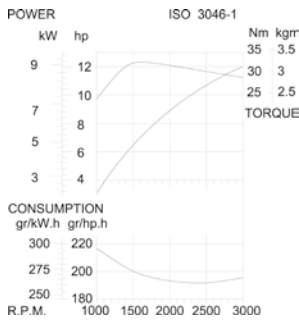

Kod /
Code

1566514



Vetus Diesel M2.18 deniz motoru

Vetus Diesel M2.18 Marine Engine, 16 HP (11.8 kW).

Motor hacmi / Capacity: 635 cm³
 Bor x strok / Bore x Stroke: 76 mm x 70 mm
 Silindir sayısı / Number of cylinder: 2
 Kompresyon oranı / Compression ratio: 23:1
 Alternatör / Alternator: 12V/75A
 Güç / Power: 16 HP (11.8 kW) (ISO 3046-1)
 Maksimum rpm / Maximum RPM: 3600
 Max. Tork 2000 rpm / Max. Torque at 2000 RPM : 35.1 Nm
 Yakıt tüketimi / Fuel consumption: 196 gr/hp/h @ 2500 rpm
 Şanzıman (standart) / Gearbox (Standard): Technodrive TMC40
 Şanzıman oranları / Gearbox ratio: 2.00:1, 2.60:1
 Opsiyonel Şanzımanlar / Optional gearbox: ZF12M (2.11:1, 2.63:1), ZF 15MIV (2.13:1, 2.99:1)
 Ağırlık (şanzıman dahil) / Weight (incl. gearbox): 107kg

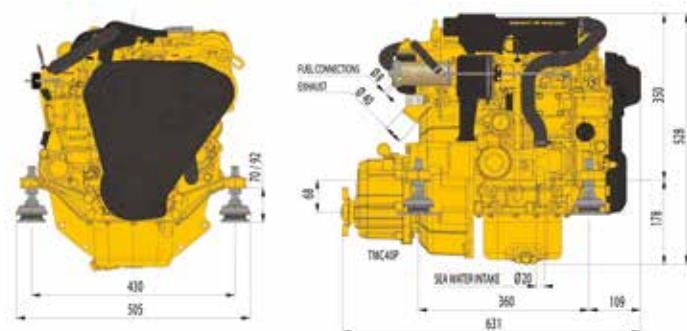
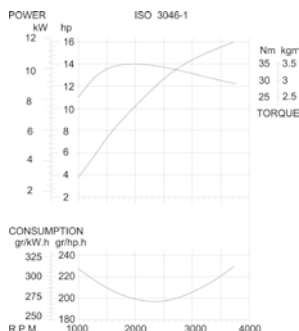

Kod /
Code

1566517



Vetus Diesel M3.29 deniz motoru

Vetus Diesel M3.29 Marine Engine, 27 HP (20 kW).

Motor hacmi / Capacity: 952 cm³
 Bor x strok / Bore x Stroke: 76 mm x 70 mm
 Silindir sayısı / Number of cylinder: 3
 Kompresyon oranı / Compression ratio: 22:1
 Alternatör / Alternator: 12V/75A
 Güç / Power: 27 HP (20 kW) (ISO 3046-1)
 Maksimum rpm / Maximum RPM: 3600
 Max. Tork 2500 rpm / Max. Torque at 2500 RPM : 30.2 Nm
 Yakıt tüketimi / Fuel consumption: 199 gr/hp/h @ 2500 rpm
 Şanzıman (standart) / Gearbox (Standard): Technodrive TMC40
 Şanzıman oranları / Gearbox ratio: 2.00:1, 2.60:1
 Opsiyonel Şanzımanlar / Optional gearbox: ZF12M (2.11:1, 2.63:1), ZF 15MIV (2.13:1, 2.99:1)
 Ağırlık (şanzıman dahil) / Weight (incl. gearbox): 134 kg

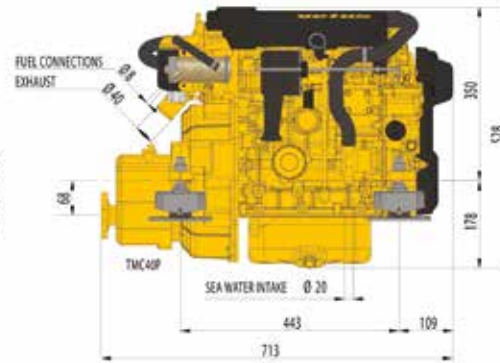
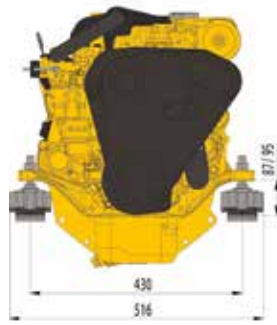
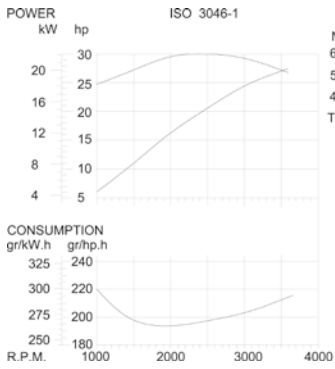

Kod / Code

1566520



Vetus Diesel M4.35 deniz motoru

Vetus Diesel M4.35 Marine Engine, 33 HP (24.3 kW).

Motor hacmi / Capacity: 1758 cm³
 Bor x strok / Bore x Stroke: 78 mm x 92 mm
 Silindir sayısı / Number of cylinder: 4
 Kompresyon oranı / Compression ratio: 22:1
 Alternatör / Alternator: 12V/110A
 Güç / Power: 33 HP (24.3 kW) (ISO 3046-1)
 Maksimum rpm / Maximum RPM: 3000
 Max. Tork 1700 rpm / Max. Torque at 1700 RPM : 83.8 Nm
 Yakıt tüketimi / Fuel consumption: 185 gr/hp/h @ 1800 rpm
 Şanzıman (standart) / Gearbox (Standard): Technodrive TMC60P
 Şanzıman oranları / Gearbox ratio: 2.00:1, 2.50:1, 2.94:1
 Opsiyonel Şanzımanlar / Optional gearbox: ZF12M (2.14:1, 2.63:1), TMC60A (2.00:1, 2.50:1)
 Ağırlık (şanzıman dahil) / Weight (incl. gearbox): 199 kg

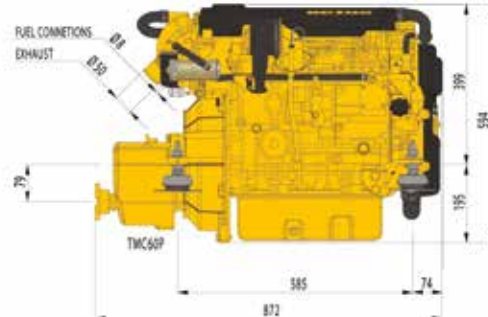
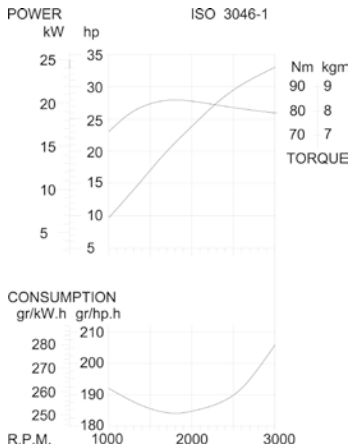

Kod / Code

1566523

M4.45

MARINE DIESEL ENGINES



Vetus Diesel M4.45 deniz motoru

Vetus Diesel M4,45 Marine Engine, 42 HP (30.9 kW).

Motor hacmi / Capacity: 1758 cm³

Bor x strok / Bore x Stroke: 78 mm x 92 mm

Silindir sayısı / Number of cylinder: 4

Kompresyon oranı / Compression ratio: 22:1

Alternatör / Alternator: 12V/110A

Güç / Power: 42 HP (30.9 kW) (ISO 3046-1)

Maksimum rpm / Maximum RPM: 3000

Max. Tork 1750 rpm / Max. Torque at 1750 RPM : 106.4 Nm

Yakıt tüketimi / Fuel consumption: 185 gr/hp/h @ 1800 rpm

Şanzıman (standart) / Gearbox (Standard): Technodrive TMC60P

Şanzıman oranları / Gearbox ratio: 2.00:1, 2.50:1, 2.94:1

Opsiyonel Şanzımanlar / Optional gearbox: ZF12M (2.14:1, 2.63:1), TMC60A (2.00:1, 2.50:1)

Ağırlık (şanzıman dahil) / Weight (incl. gearbox): 199 kg

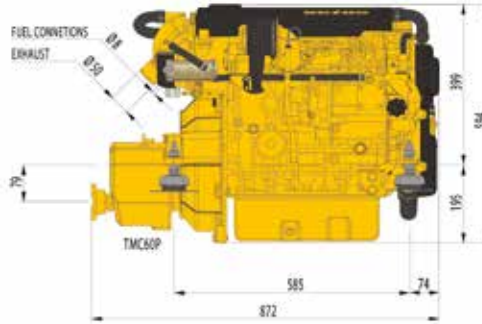
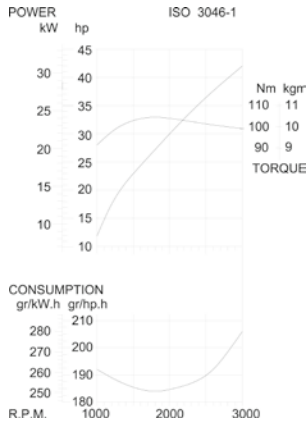

Kod /
Code

1566526

M4.56

MARINE DIESEL ENGINES



Vetus Diesel M4.56 deniz motoru

Vetus Diesel M4,56 Marine Engine, 52 HP (38.3 kW).

Motor hacmi / Capacity: 1758 cm³

Bor x strok / Bore x Stroke: 78 mm x 92 mm

Silindir sayısı / Number of cylinder: 4

Kompresyon oranı / Compression ratio: 22:1

Hava Girişi / Intake: Turbo Charged

Alternatör / Alternator: 12V/110A

Güç / Power: 52 HP (38.3 kW) (ISO 3046-1)

Maksimum rpm / Maximum RPM: 3000

Max. Tork 2000 rpm / Max. Torque at 2000 RPM : 127 Nm

Yakıt tüketimi / Fuel consumption: 179 gr/hp/h @ 1800 rpm

Şanzıman (standart) / Gearbox (Standard): TM345A

Şanzıman oranları / Gearbox ratio: 2.00:1, 2.50:1, 2.94:1

Opsiyonel Şanzımanlar / Optional gearbox: ZF12M (2.14:1, 2.63:1), ZF 15MIV (2.13:1, 2.99:1)
TMC60P (2.00:1, 2.50:1)

Ağırlık (şanzıman dahil) / Weight (incl. gearbox): 206 kg

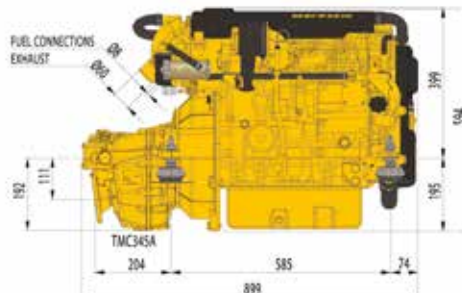
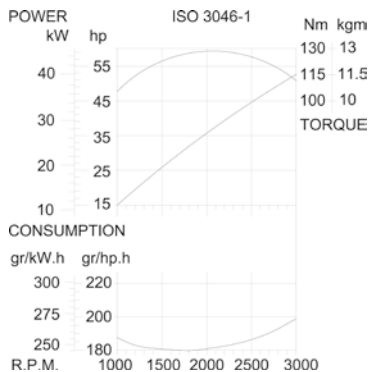

Kod /
Code

1566529



Motor Hacmi / Capacity	: 2,607 cm ³
BorxStrok / BorexStroke	: 91,1x100 mm
Silindir Sayısı / Number of cylinder	: 4
Kompresyon Oranı / Compression ratio	: 22:1
Alternatör / Alternator	: 12V / 115A
Güç / Power	: 65,3 HP (48 KW) (ISO 3046-1)
Maksimum RPM / Maximum RPM	: 3,000
2,200 RPM de Tork / Torque at 2200 RPM	: 170 Nm
Şanzıman (Standart) / Gearbox (Standard)	: TM345 (HYDR)
Şanzıman Oranı / Gearbox ratio	: 2.00:1, 2.47:1
Opsiyonel Şanzıman / Optional gearbox	: ZF25A - 1.93:1, 2.29:1, 2.71:1
Ağırlık (Şanzıman Dahil) / Weight (incl. gearbox)	: 240 Kg

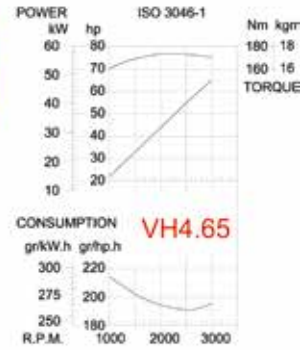
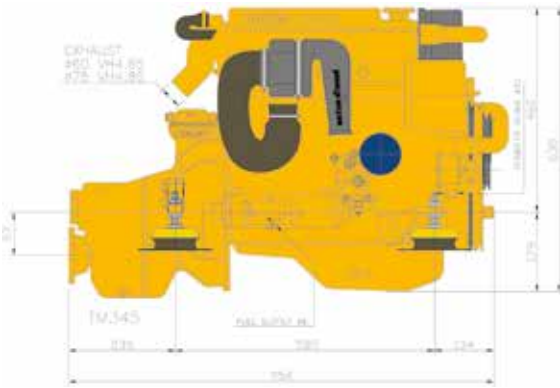

Kod / Code

1566532



Motor Hacmi / Capacity	: 2,607 cm ³
BorxStrok / BorexStroke	: 91,1x100 mm
Silindir Sayısı / Number of cylinder	: 4
Kompresyon Oranı / Compression ratio	: 22:1
Alternatör / Alternator	: 12V / 115A
Güç / Power	: 80,3 HP (59 KW) (ISO 3046-1)
Maksimum RPM / Maximum RPM	: 4,000
2,200 RPM de Tork / Torque at 2200 RPM	: 170 Nm
Şanzıman (Standart) / Gearbox (Standard)	: TM345 (HYDR)
Şanzıman Oranı / Gearbox ratio	: 2.00:1, 2.47:1
Opsiyonel Şanzıman / Optional gearbox	: ZF25A - 1.93:1, 2.29:1, 2.71:1
Ağırlık (Şanzıman Dahil) / Weight (incl. gearbox)	: 240 Kg

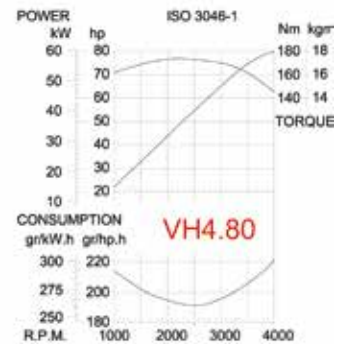
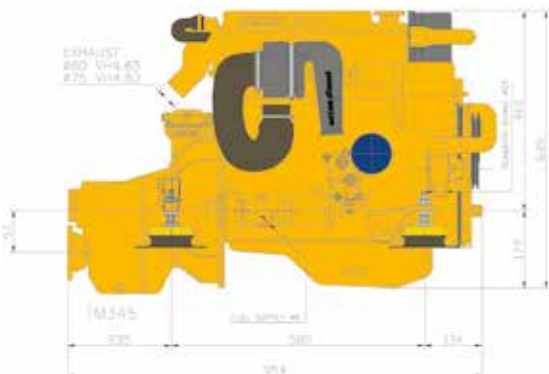

Kod / Code

1566535



Yeni geliştirilen ZF marka Saildrive ünitesi 13 HP'den, 80HP'ye kadar olan tüm sarı seri Vetus motorlarında uygulanmaktadır. Motor gücü ile Pervane/ Sürat parametrelerine uygun olarak, ileri ve tornistan konumunda aynı performansı alabilme açısından, iki redüksiyon oranı uygun görülmüştür (2.15:1 veya 2.38:1). Redüksiyon oranları ileri veya tornistan konumunda değişmemektedir. Bu uygulama ile bir makinanın pervanesinin saat yönünde, diğerinin de ters dönüşlü çalışabilme imkanı sağlanarak özellikle çift makine montajı için son derece uygun olmuştur. Her iki redüksiyon uygulamasında, saildrive boyut ve ebatları değişmemektedir. Örnek olarak aşağıdaki M4.45 tipi (42 Beygir) çizimdeki ölçülendirmelere bakabilirsiniz. Vetus Saildrive ünitesinin bir diğer avantajı ise 180° dönerek, tahrik kuyruğunun istenirse motorun arkasında, istenirse de motorun önüne gelecek şekilde monte edilebilmesi sayesinde, üstün montaj esnekliği de sağlanmıştır.

This newly developed ZF Saildrive unit is available for all yellow series Vetus marine diesel engines from 13 HP up to 80HP. Two transmission ratios (2.15:1 or 2.38:1) have been selected to match engine power and speed to propeller size with identical ratios both ahead and astern. This feature is ideal for twin-engine installation with clockwise and counter clockwise propellers. The overall dimensions are identical for both ratios. As an example, please see the installation drawing of engine model M4.45 below. Another advantage of this sail drive is that the underwater drive leg can be fitted 180° reversed. This will permit the engine to be installed ahead or behind the sail drive unit for greater flexibility of installation.

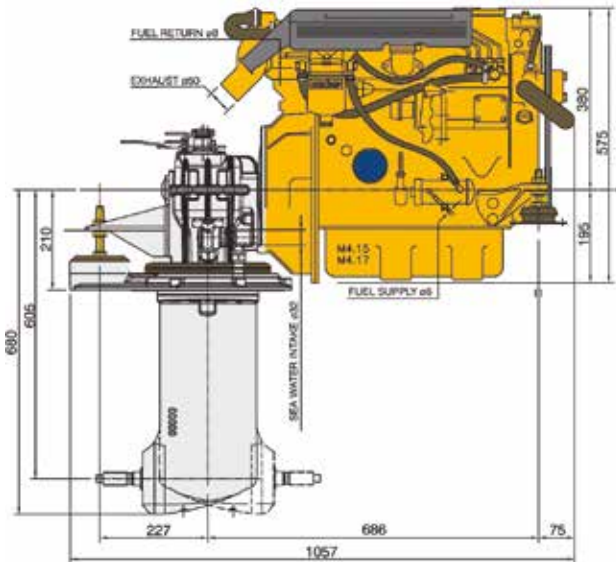

Teknik Veriler / Technical Data:

Şanzıman Redüksiyon oranı (ileri ve geride değişmez) / : 2.15-1

Transmission ratio (ahead and astern)

Maksimum giriş tork değeri / Maximum input torque : 155 Nm

Şanzıman Redüksiyon oranı (ileri ve geride değişmez) / : 2.38-1

Transmission ratio (ahead and astern)

Maksimum giriş tork değeri / Maximum input torque : 147 Nm

Dişli Mekanizması / Gear mechanism

: Tork limitörü sayesinde aşırı yüke karşı korunmuştur. / Protected against overload by incorporated torque limiter.

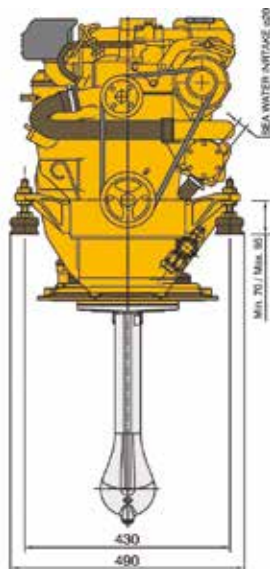

Önerilen Redüksiyon Oranları / Recommended transmission ratios

M2.13	13 hp @ 3000 r.p.m	Redüksiyon / Ratio 2.15:1
M2.18	16 hp @ 3600 r.p.m	Redüksiyon / Ratio 2.38:1
M3.29	27 hp @ 3600 r.p.m	Redüksiyon / Ratio 2.15:1
M4.35	33 hp @ 3000 r.p.m	Redüksiyon / Ratio 2.15:1
M4.45	42 hp @ 3000 r.p.m	Redüksiyon / Ratio 2.15:1
M4.65	65 hp @ 3000 r.p.m	Redüksiyon / Ratio 2.15:1
M4.80	80 hp @ 4000 r.p.m	Redüksiyon / Ratio 2.38:1

Opsiyonlar:

- Üniversal fiberglass motor yatağı (M2.13 - M2.18 - M3.29 - M4.35 ve M4.45 motorlar için). (STM 9320)
- Üniversal fiberglass motor yatağı (VH 4.65 ve VH 4.80 için) (STM 9321)

Options:

- Universal GRP engine bed, for models M2.13 - M2.18 - M3.29 - M4.35 and M4.45 (STM 9320)
- Universal GRP engine bed, for models VH 4.65 and VH 4.80. (STM 9321)



Motor Hacmi / Capacity	: 4.040 cm ³
BorxStrok / BorexStroke	: 101X126 mm
Silindir Sayısı / Number of cylinder	: 4
Kompresyon Oranı / Compression ratio	: 18:1
Alternatör / Alternator	: 12V / 160A - 24V / 80A
Güç / Power	: 122 HP (90 KW) (ISO 8665)
Maksimum RPM / Maximum RPM	: 2400
Maksimum RPM de Tork / Torque at maximum RPM	: 449 Nm 1600 RPM
Yakıt Tüketimi / Fuel consumption	: 295 g/Kw h.
Şanzıman (Standart) / Gearbox (Standard)	: ZF 45
Şanjman Oranı / Gearbox ratio	: 2.2 / 2.51 / 3.1
Opsiyonel Şanzıman / Optional gearbox	: ZF45A - 1.26:1 - 1.51 - 2.03
Ağırlık (Şanzıman Dahil) / Weight (incl. gearbox)	: 532 Kg

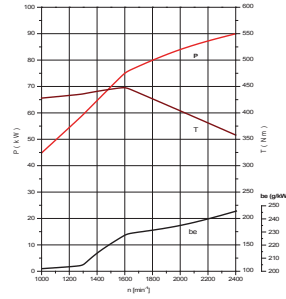
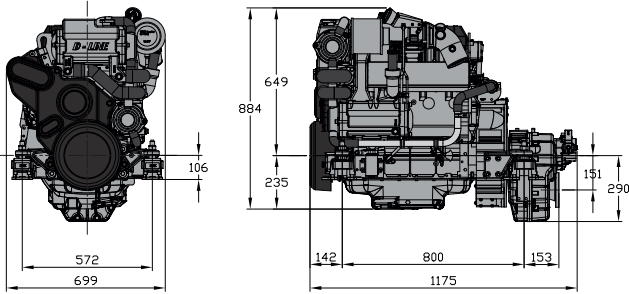

Kod / Code

1566538



Motor Hacmi / Capacity	: 4.040 cm ³
BorxStrok / BorexStroke	: 101X126 mm
Silindir Sayısı / Number of cylinder	: 4
Kompresyon Oranı / Compression ratio	: 18:1
Alternatör / Alternator	: 12V / 160A - 24V / 80A
Güç / Power	: 140 HP (103 KW) (ISO 8665)
Maksimum RPM / Maximum RPM	: 2400
Maksimum RPM de Tork / Torque at maximum RPM	: 520 Nm 1600 RPM
Yakıt Tüketimi / Fuel consumption	: 235 g/Kw h.
Şanzıman (Standart) / Gearbox (Standard)	: ZF 45
Şanjman Oranı / Gearbox ratio	: 2.2 / 2.51 / 3.1
Opsiyonel Şanzıman / Optional gearbox	: ZF45A - 1.26:1 - 1.51 - 2.03
Ağırlık (Şanzıman Dahil) / Weight (incl. gearbox)	: 532 Kg

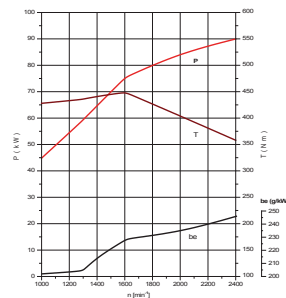
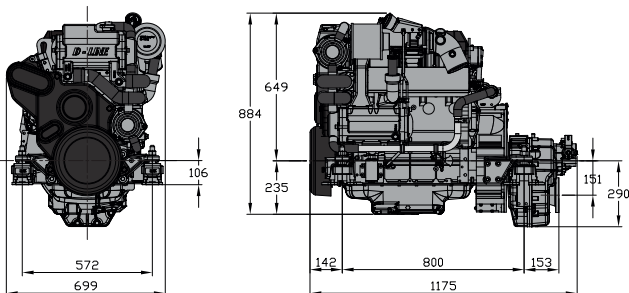

Kod / Code

1566540

VD6.170 COMMON RAIL TURBO ŞARJLI / TURBO CHARGED

MARINE DIESEL ENGINES

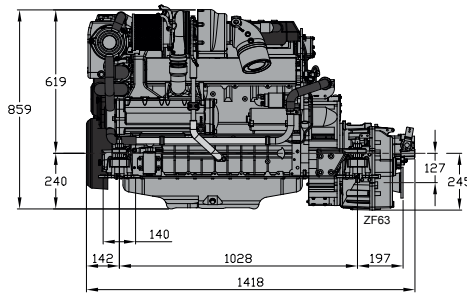
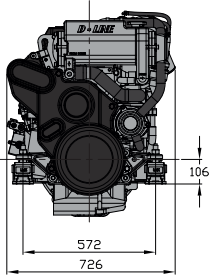

Motor Hacmi / Capacity	: 6.060 cm ³
BorxStrok / BorexStroke	: 101X126 mm
Silindir Sayısı / Number of cylinder	: 6
Kompresyon Oranı / Compression ratio	: 18:1
Alternatör / Alternator	: 12V / 160A - 24V / 80A
Güç / Power	: 170 HP (125 KW) (ISO 8665)
Maksimum RPM / Maximum RPM	: 2400
Maksimum RPM de Tork / Torque at maximum RPM	: 680 Nm 1600 RPM
Yakıt Tüketimi / Fuel consumption	: 240 g/Kw h.
Şanzıman (Standart) / Gearbox (Standard)	: ZF 63
Şanzıman Oranı / Gearbox ratio	: 1.51 / 1.93 / 2.48
Opsiyonel Şanzıman / Optional gearbox	: ZF63A - 1.22:1 - 1.56 - 2.04
Ağırlık (Şanzıman Dahil) / Weight (incl. gearbox)	: 657 Kg

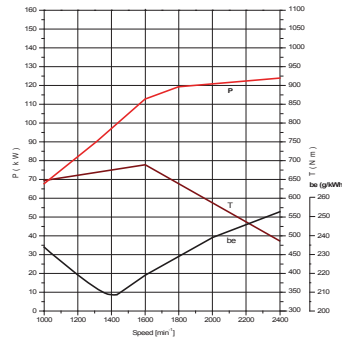

Kod / Code

1566542

VD6.210 COMMON RAIL TURBO ŞARJLI / TURBO CHARGED

MARINE DIESEL ENGINES

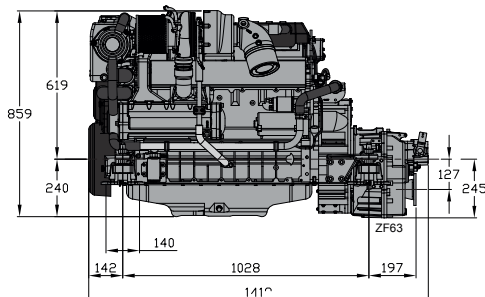
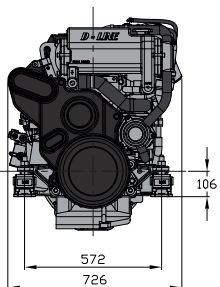

Motor Hacmi / Capacity	: 6.060 cm ³
BorxStrok / BorexStroke	: 101X126 mm
Silindir Sayısı / Number of cylinder	: 6
Kompresyon Oranı / Compression ratio	: 18:1
Alternatör / Alternator	: 12V / 160A - 24V / 80A
Güç / Power	: 210 HP (155 KW) (ISO 8665)
Maksimum RPM / Maximum RPM	: 2400
Maksimum RPM de Tork / Torque at maximum RPM	: 810 Nm 1600 RPM
Yakıt Tüketimi / Fuel consumption	: 240 g/Kw h.
Şanzıman (Standart) / Gearbox (Standard)	: ZF 63
Şanzıman Oranı / Gearbox ratio	: 1.51 / 1.93 / 2.48
Opsiyonel Şanzıman / Optional gearbox	: ZF63A - 1.22:1 - 1.56 - 2.04
Ağırlık (Şanzıman Dahil) / Weight (incl. gearbox)	: 657 Kg

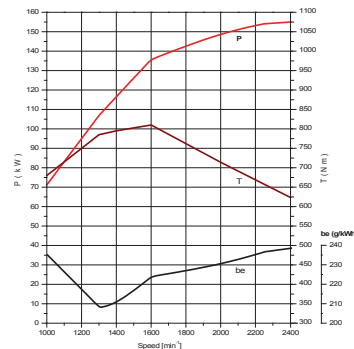

Kod / Code

1566544