



CARRELLI PORTA IMBARCAZIONI RADIOCOMANDATI A DISTANZA



ALTO SERVICE ITALIA s.r.l.



CARRELLO MOTORIZZATO RADIOCOMANDATO A DISTANZA P



PER SOLLEVAMENTO E MOVIMENTAZIONE DI IMBARCAZIONI

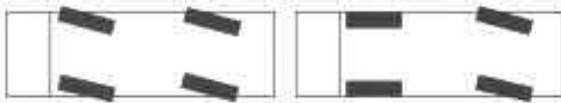

- Quattro gruppi di ruote sterzanti permettono un corto raggio di sterzata
- Above: four-wheel hydraulic steering and two wheel drives permit dead on precision in confined spaces
- Ci dessous: Quatre roues directrices procurent un très court rayon de braquage
- Allrad-Lenkung erlaubt beste Manövrierfähigkeit mit engsten Lenkradien

M. 15
M. 20
M. 30
M. 40
M. 50
M. 60
M. 80
M. 100
M. 120
M. 140
M. 160
M. 180
M. 200

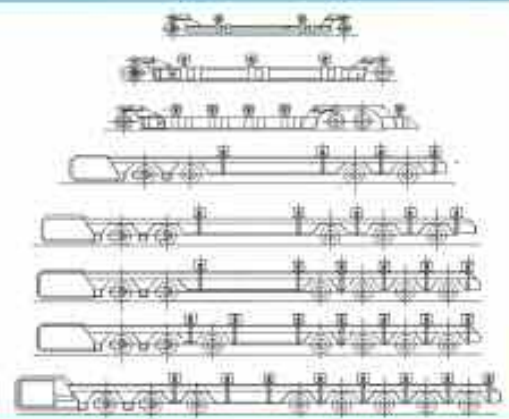

CARRELLI MOTORIZZATI RADIOCOMANDATI A DISTANZA

MOTORIZED TRAILERS
TO CARRY BOAT WITH
REMOTE CONTROL

CHARIOTS PORTE-
EMBARCATIONS
MOTORISÉS AVEC
RADIO COMMANDE

MOTORSIERTE TRAILER
MIT FUNKSTEUERUNG

CARRELLI TRAINATI

TOWABLE TRAILERS

CHARIOTS TRACTABLES

ZIEHBARER WAGEN

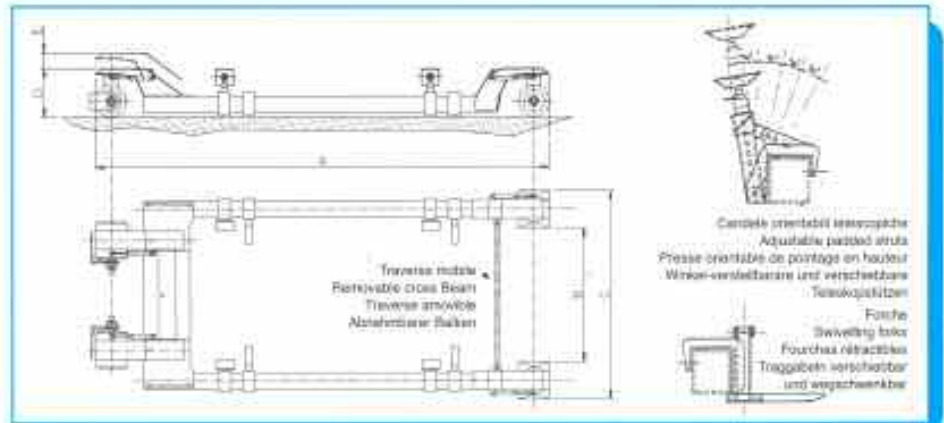

Modello	M. 15 M. 20	M. 30 M. 40	M. 50 M. 60	M. 80	M. 100 M. 120	M. 140	M. 160	M. 180	M. 200
Portata (TON)	10-20	30-40	50-60	80	100-120	140	160	180	200
Motore (HP)	28	47	65	84	118	130	140	160	170
Velocità (Km/h)	2	2	2	2	2	2	2	2	2
A - Lunghezza mm	7700	10900	12500	15800	18000	18000	19000	20000	20000
B - Larghezza interna mm	2180 2150	2760 2720	2760 2720	2720	2920	3000	3000	3000	3000
C - Larghezza esterna mm	3420 3500	4440 4500	440 4480	440	4500	4750	4750	4750	4750
D - Altezza carrello mm	795 830	990 1040	1020 1070	1085	1085	1200	1200	1200	1200
E - Corsa di sollevamento	250	300	300	300	300	300	300	300	300

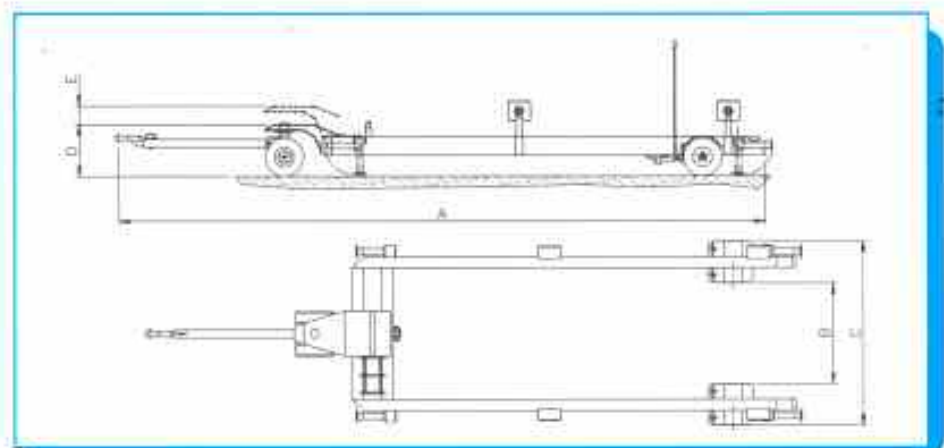

Model	T.10	T.15	T.25	T.35
Portata (TON)	10	15	25	35
A - Lunghezza mm	6800	7800	8900	9900
B - Larghezza interna mm	1350	1500	2200	1800
C - Larghezza esterna mm	2470	2840	3200	3400
D - Altezza carrello mm	500	600	700	850
E - Corsa di sollevamento mm	200	200	300	300

CARRELLI BREVETTATI - MOTORIZZATI O TRAINABILI PER IL SOLLEVAMENTO E LA MOVIMENTAZIONE DI IMBARCAZIONI

Sono costituiti in acciaio elettrosaldato ad alta resistenza, azionati da sistema idraulico, forniti di radiocomando a distanza, dotato di sistemi di sicurezza che neutralizza ogni interferenza esterna.

Il radiocomando consente di azionare le seguenti movimentazioni:

- 1) Marcia avanti ed indietro con velocità proporzionale;
- 2) Sollevamento e discesa, anteriore e posteriore indipendente;
- 3) Sterzata delle ruote anteriori e posteriori indipendente.

I gruppi ruota sono tutti autolivellanti, basculanti e sterzanti.

I carrelli sono dotati di forche rientranti, che si inseriscono sotto le invasature delle imbarcazioni, e di candele telescopiche orientabili che si appoggiano sotto lo scafo dei natanti, sollevandolo e lasciando sul posto le invasature gli eventuali toccaggi.

I carrelli **ALTO SERVICE** essendo completamente aperti nella parte posteriore, per inserirsi sotto i natanti, consentono di movimentare le imbarcazioni, senza l'ausilio di nessun altro mezzo ingombrante di sollevamento e garantiscono con la massima facilità di manovra, l'utilizzo degli spazi più ristretti e di difficile accesso, in diversi modelli (da 10 a 200 Ton.). La Ditta si riserva il diritto di modificare le caratteristiche per il miglioramento del prodotto.

CHARIOTS BRÉVETÉS MOTORISÉS OU TRAINÉS POUR HISSAGE ET MOUVEMENT DES EMBARCATIONS

Costruits en acier electro-soudé à grande résistance - commandés par système hydraulique - munis de radiocommande et de dispositif de sureté qui neutralise interferences extérieures.

Le radiocommande permet les mouvements suivants:

- 1) Marche avant-arrière avec vitesse proportionnelle;
- 2) Soulevement et descente antérieures et postérieures indépendents;
- 3) Braquage des roues avant et arrière indépendant.

Les groupes roues sont auto-nivelantes, basculantes et barquantes.

Les chariots sont munis de fourches retractibles qui s'insèrent sous les bers des embarcations et de presses orientables de pointage en hauteur (avec eventuelles prolonges pour bateaux à voiles) qui se placent sous le coque des bateaux, en les soulevant et en laissant sur place les bers et eventuelles cales.

Les chariots **ALTO SERVICE** étant entièrement ouvertes en arrière pour s'insérer sous les bateaux, permettent de les mouvoir sans l'aide d'autres moyens entre les espaces le plus étroites et d'accès difficile.

Les chariots sont produits en series en plusieurs modèles de 10 à 200 tons.

ALTO SERVICE se réserve le droit de modifier les caracteristiques pour l'amélioration du produit.

PATENTED MOTOR-DRIVEN OR TOWED TRAILERS FOR BOATS LIFTING AND HANDLING

- High strength steel welded structure.
- Hydraulic driven and remote operated by radio control.
- Equipped with safety device neutralising every external interference.
- The radio controlled system allows easy manoeuvrability:
 - 1) Proportional speed forward-reverse running.
 - 2) Independent front and back lifting and descent.
 - 3) Independent front and back wheels steering.
- Wheel sets are all self-levelling, balancing and steering. The trailers are equipped with re-entering forks that can be easily inserted under the boat sliding ways.
- The swinging telescopic bars (with optional extensions for sail boats), once positioned under the hull can lift the boat and leave sliding ways and keelblocks in their original spot.

The **ALTO SERVICE** trailers, being completely open at back allows for easy positioning and handling without the need for other bulky lifting devices.

The **ALTO SERVICE** trailers, provide complete manoeuvrability in difficult situations even in the narrowest areas.

The **ALTO SERVICE** trailers are produced in series in different models from 10 to 200 tons. **ALTO SERVICE** reserve the right to modify the characteristics in order to improve the trailer performances.

MOTORISIERTE ZIEHBARE TRAILER FÜR DEN LANDTRASPORT VON SCHIFFEN

Die Rahmen besteht aus elektrogeschweissten Stahlprofilen hoher Festigkeit.

Per Funkfernsteuerung wird der motorisierte Trailer vorwärts und rückwärts gefahren, und gelenkt, sowie angehoben und abgesenkt.

Die Räder sind kardanisch aufgehängt.

Die Traggabeln für den Transport von Schiffen in Gestellen können geschwenkt und zur Anpassung an die Länge des Gestells auf dem Rahmen verschoben werden. Die Teleskopstützen für den Schifftransport ohne Gestell sind im Winkel verstellbar, in der Höhe veränderbar und auf dem Rahmen längsverschiebbar. Verlängerungen für den Segelboottransport sind lieferbar. Die Trailer von **ALTO SERVICE** sind hinten vollständig offen, um einfachste Positionierung unter dem Schiff zu ermöglichen.

Sie sind konzipiert für den Gebrauch unter räumlich beengten Verhältnissen, um die zur Verfügung stehende Fläche optimal ausnutzen zu können.

Der motorisierte Trailer ist lieferbar mit einer Tragfähigkeit von 15 bis 200 t, der gezogene mit einer von 10 bis 35 t.

Der Hersteller behält sich das jederzeitige Recht zu Technischen Änderungen vor.



ALTO SERVICE ITALIA s.r.l.

Via Calegrande, 9b - Via di Vittorio, 27 - Z.I.

Tel. 0039/0584/969685 - 969518

Fax 0039/0584/969457 - 969662

55040 CAPEZZANO PIANORE (LU) Italy

E-mail: altoservice@altoservice.it

Web: <http://www.altoservice.it>

16 02. 2005